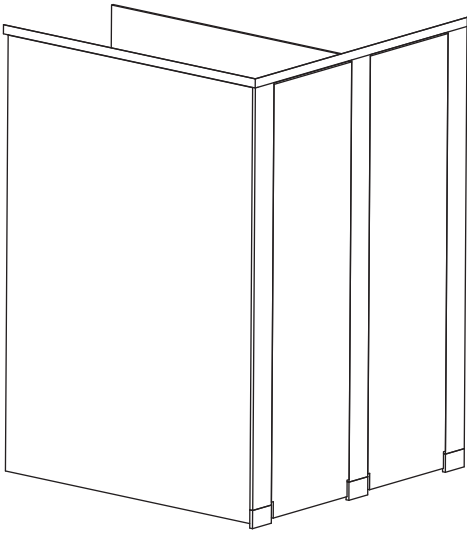


INSTALLATION INSTRUCTIONS EXTENDED PRIVACY

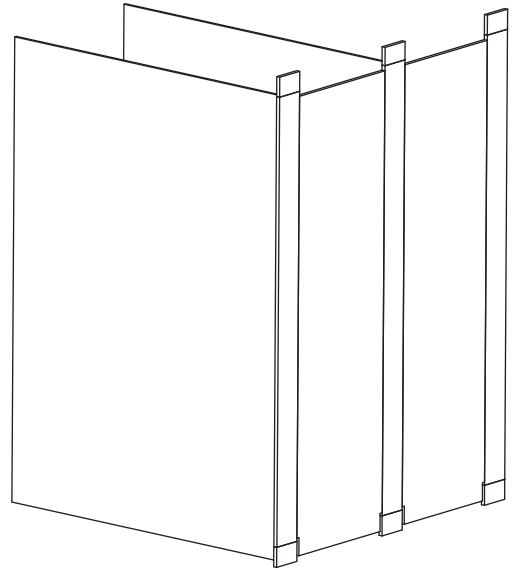
COMPACT GRADE LAMINATE (CGL)
TOILET PARTITIONS

3080G.67P DuraLineSeries® • 3180G.67P DuraLineSeries® Class-A Fire Rated

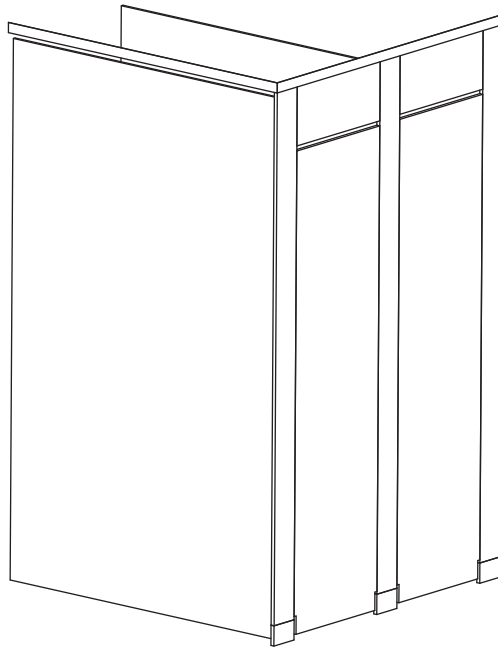
Overhead Braced



Floor-to-Ceiling
Anchored



Overhead Braced
Transom Panel



**IMPORTANT: Storage and Handling Information on last page.
Review these instructions thoroughly prior to installation.**

PREPARATION

PRE-INSTALLATION

- A. Structural support in walls and floors is not furnished by Bobrick. Confirm that adequate backing is present in wall, ceilings, and floors prior to installation.
- B. This installation booklet must be used with the Bobrick layout sheets.
- C. You may verify hardware receipt by cross-referencing the last page of the layout sheets against the box contents.

INSTALLATION STEPS





- 1. Lay Out All Anchor Locations Page 3
- 2. Install Floor Anchors Page 4
- 3. Install Wall Brackets..... Page 7
- 4. Position Panels..... Page 8
- 5. Install Stile-To-Panel Brackets..... Page 9
- 6. Install Stiles and Set Door Openings..... Page 10
- 7. Install Headrail (if applicable) Page 11
- 8. Install Inswing or Outswing Doors Page 12
- 9. Install Occupancy Latch & Keeper Page 14
- 10. Install Wall Mounted Keeper (if applicable)..... Page 16
- 11. Install Door Stop Page 17
- 12. Install Robe Hook and Door Pulls..... Page 18
- 13. Install Transom Panel (if applicable) Page 19
- 14. Install Shoes Page 20
- 15. Finishing and Cleanup. Page 20

ADDITIONAL TIPS

- A. Organize components with appropriate hardware.
- B. When calculating distances to centerlines, stiles, and doors are 3/4" (19mm) thick; panels are 1/2" (13mm) thick.
- C. Look for panel-to-stile offsets indicated on the layout sheets.
- D. Pilot hole sizes vary by application. Read all directions carefully and use a drill stop to ensure you do not drill through material in error.
- E. Doors are not pre-drilled for clothes hooks.
- F. On inswing doors the latch track projects past the edge of door to act as a doorstop.
- G. Keepers are not drilled to allow easier stile leveling.
- H. Remove debris from all drilled holes.

RECOMMENDED TOOLS.

CAUTION: Be sure to use proper safety gear.

- 1.  Chalk Line
- 2.  Self Leveling Laser Device
- 3.  Masking Tape (for laying out holes on floors/walls/ceilings to be drilled)
- 4.  Tape Measure and Pencils
- 5.  Center Punch
- 6.  Electric and/or Battery-Powered Drill
- 7.  Drill Bits
#19 (.166")
3/16" (4.7mm)
3/8" (9.5mm) for Concrete/Masonry
7/16" (11mm)
- 8.  Screwdrivers/Screwdriver Bits flathead and phillips, #2 and #3
- 9.  Pin-in-Head Torx Screw Driver - (to install door hardware)—Supplied by Bobrick.
- 10.  Shims
- 11.  Adjustable Supports
1-1/2" to 12" (40-105mm)
- 12.  Level
- 13.  Wrench - Adjustable 9/16" (14mm) open end (2 req'd. for adjusting hex nuts on anchors)
- 14.  Allen Wrench - 5/64" (2mm) (to install door latch)—Supplied by Bobrick.
- 15.  Hack Saw
- 16.  Hammer

STEP 1

LAY OUT ALL ANCHOR LOCATIONS

- A. Refer to Bobrick layout sheets for component locations on your specific application.
 - B. From back wall, measure and mark the location of the stile centerline. Stile centerline = 3/8" (10mm) + panel length + gaps specified on layout sheets.
 - C. From side wall at centerline of stile, measure dimensions for floor or ceiling anchors according to layout sheet. Refer to drilling table below for center-to-center distances between anchors. Centerline of floor anchor from edge of stile is 5/8" (16mm); dimension on 3" (76mm) stile is 1 1/2" (38mm).
- ◇ Obtain Dimension from Bobrick Layout Sheet.

Fig. 1a: Overhead-Braced Alcove Closed Layout.

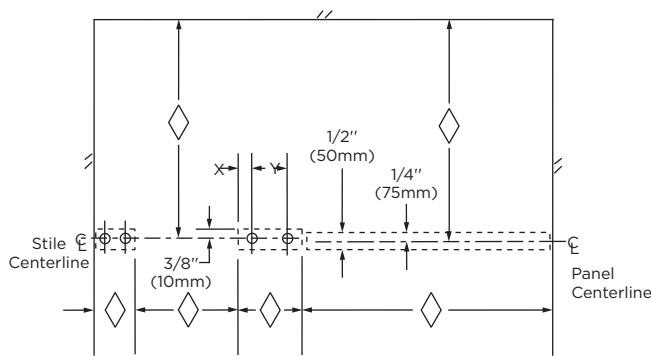
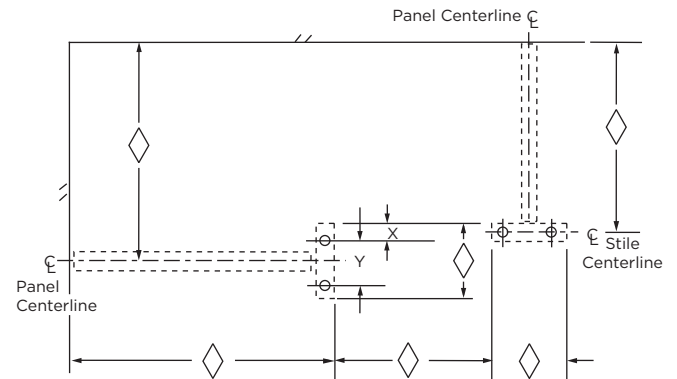


Fig. 1b: Floor-Anchored or Ceiling-Hung Alcove Open Layout.



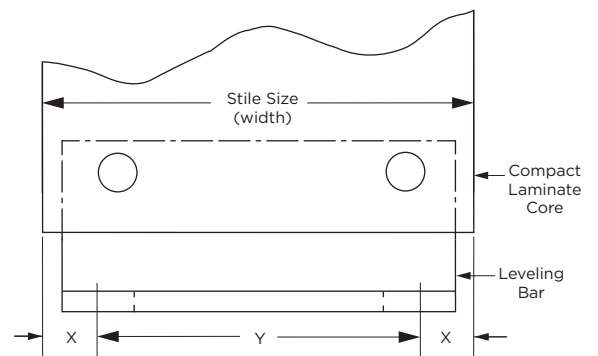
Note: The stiles are inline with panel.

Note: The center stile is perpendicular to panel.

Drilling Table For Drilling Floor Or Ceiling Anchors

Stile Size (width)	Number of Holes	X Dimension	Y Dimension
3" (76mm)	1	1 1/2" (38mm)	—
4" (102mm)	2	5/8" (16mm)	2 3/4" (70mm)
5" (127mm)	2	5/8" (16mm)	3 3/4" (95mm)
6" (152mm)	2	5/8" (16mm)	4 3/4" (121mm)
7" (178mm)	2	5/8" (16mm)	5 3/4" (146mm)
8" (203mm)	2	5/8" (16mm)	6 3/4" (171mm)
10" (254mm)	2	5/8" (16mm)	8 3/4" (222mm)
12" (305mm)	2	5/8" (16mm)	10 3/4" (273mm)
16" (406mm)	2	5/8" (16mm)	14 3/4" (375mm)
18" (457mm)	2	5/8" (16mm)	16 3/4" (425mm)
20" (508mm)	2	5/8" (16mm)	18 3/4" (476mm)
24" (610mm)	2	5/8" (16mm)	22 3/4" (578mm)

Fig. 1c: Detail of Typical Stile



Note: 16", 18", 20", 24" (406, 457, 508, 610mm) stiles have two leveling bars. Use the two outside slots for the two anchors.

STEP 2

INSTALL FLOOR ANCHORS

Parts Needed: #1002701 Floor Anchor Packet (includes: 3 Hex Nuts, 3 Flat Washers, Wedge Anchor, Lock Washer, Flat Shoe Retainer)

Note: 3/8" x 2" (M9.5 x 50mm) hole needed to install #1002701 Floor Anchor. Use concrete/masonry drill bit.

Fig. 2a: Finished Detail of #1002701 Floor Anchor - Side View.

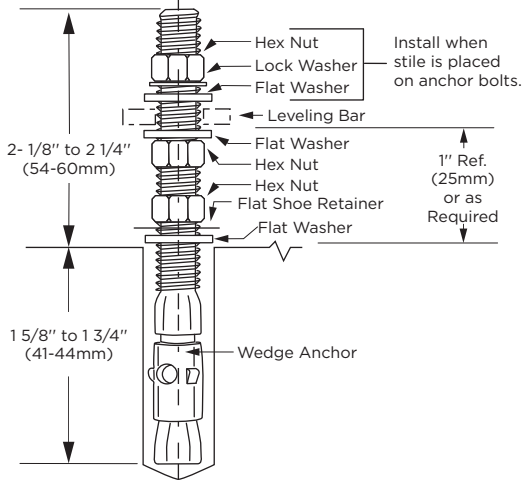
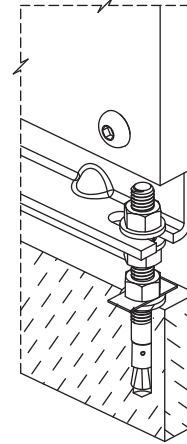
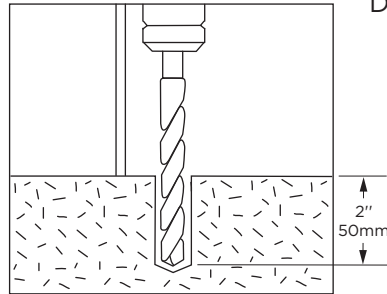


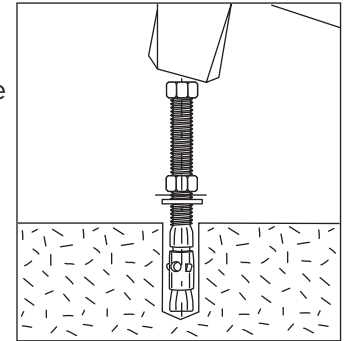
Fig. 2b: Floor Anchor Attached to Stile - 3D Top Side View.



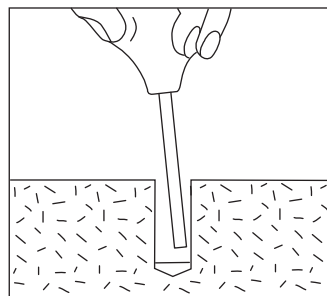
A. Drill a 3/8" (9.5mm) hole to 2" (50mm) minimum depth.



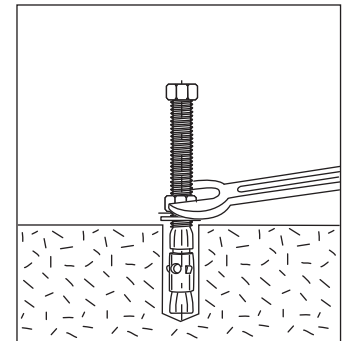
D. Insert Anchor into hole with threaded end up. Use hammer to drive the Anchor into hole until Flat Washer is flush with concrete surface (depth set in **Step 2.C**).



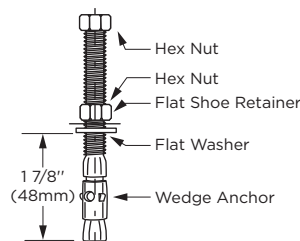
B. Remove all loose material/debris from hole.



E. Use Wrench to tighten Hex Nut until anchor is firmly set (2-4 full turns past finger tight position). Anchor bolt will move up approx. 1/16" (1.6mm) for every full turn of Hex Nut.

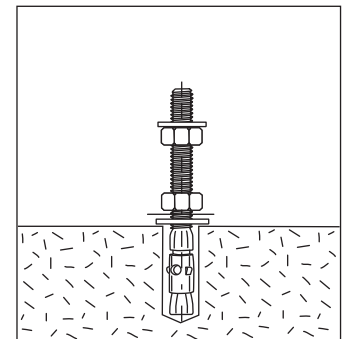


C. Add Flat Washer, Flat Shoe Retainer, Hex Nut to Wedge Anchor so that Flat Washer is 1 7/8" (48mm) from the bottom of the anchor to ensure proper installation depth. Thread 2nd Hex Nut loosely to top of Anchor to prevent stripping or damaging threads during installation.



F. Spin down top Hex Nut. Add Flat Washer.

Note: Do not add third Hex Nut, Lock Washer, and third Flat Washer until stiles are attached to Floor Anchor.



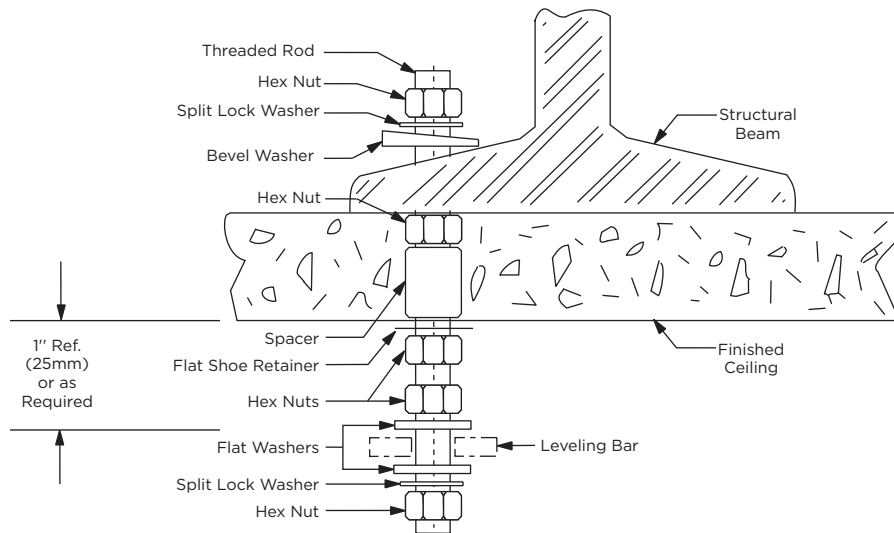
STEP 2

INSTALL ALL ANCHORS

Note: Ceiling anchors are to be installed before finished ceiling is applied. All structural framing is to be furnished by others. For Bobrick recommendations, refer to Bobrick Form No. TB-32.

- A. Drill 7/16" (11mm) diameter hole through structural beam. Insert threaded rod through hole in beam. Rod is furnished standard 6" (150mm) length. Longer rods should be purchased locally if required.
- B. Drop a bevel washer and lock washer over rod. Screw on one hex nut.
- C. Install second hex nut against bottom of beam and tighten.
- D. Install spacer, shoe retainer, and a third hex nut. Make sure shoe retainer is in proper position to accept shoe (see **Fig. 2b** or **2c** for proper shoe retainer position).
- E. Install remaining flat washers (2), lock washer (1), and hex nuts (2), as shown in **Fig. 2c**.
- F. Repeat process for each ceiling anchor.

Fig. 2c: Detail of Ceiling Anchor.



BRACKETS AND SCREWS

Angle Bracket

1" (25.4mm)
2" (51mm)



#319618-7XL
(L= Length)

2 each for:
Stile-to-Wall or
Panel-to-Wall

Z-Bracket

2" (51mm)



#319618-6XL
(L= Length)

Panel Inline
with Stile

U-Channel Bracket

2" (51mm)



#319618-8XL
(L= Length)

Internal
Panel-to-
Wall



#1002499

#12 x 7/16" Pin-Head Torx
Screw (M5.5 x 11mm)
Panel/Stile Screw Channel to
Stile Screw



#1002495

#12 x 2" Pin-Head Torx Screw
(M5.5 x 50mm) Wall Screw

Continuous Bracket Length Guide

Chart Applicable for 1" (25.4mm) Floor Clearance Only:

Panel Height Range	Angle Bracket (to wall) Length	U-Channel Length, Z-Bracket Length & Angle Bracket (to panel) Length
73" (1854mm) - 78" (1981mm)	68 1/4" (1734mm)	68 1/4" (1734mm)
79" (2007mm) - 85" (2159mm)	75 1/4" (1911mm)	75 1/4" (1911mm)
86" (2184mm) - 91" (2311mm)	82 1/4" (2089mm)	82 1/4" (2089mm)
92" (2337mm) - 96" (2438mm)	88 1/4" (2242mm)	88 1/4" (2242mm)

Chart Applicable for 4-1/2" (114mm), 9" (229mm) and 12" (305mm) Floor Clearance:

Panel Height Range	Angle Bracket (to wall) Length	U-Channel Length, Z-Bracket Length & Angle Bracket (to panel) Length
73" (1854mm) - 78" (1981mm)	71 1/2" (1816mm)	71 1/2" (1816mm)
79" (2007mm) - 85" (2159mm)	78 1/2" (1994mm)	78 1/2" (1994mm)
86" (2184mm) - 91" (2311mm)	85 1/2" (2172mm)	85 1/2" (2172mm)
92" (2337mm) - 96" (2438mm)	91 1/2" (2324mm)	91 1/2" (2324mm)

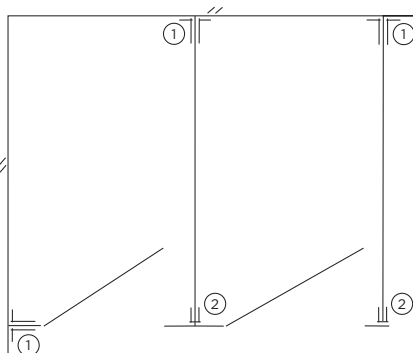
Pilot Hole Sizes: 3/16" x 7/16" (4.7 x 11mm), #19 (.166) x 2" (50mm)

Note: Adequate wall backing is required. High-quality drill bit is suggested for drilling into Compact Laminate material.

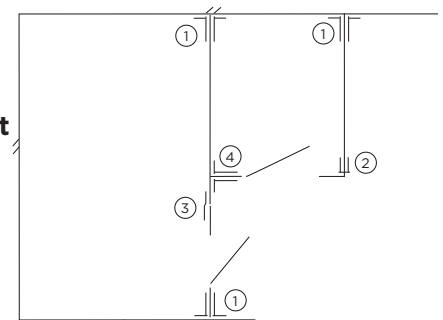
Example Bracket Applications

- 2 Quantity - **319618-7XL** Angle Bracket:
Use #1002499 Torx Screw for Panel Attachment
Use #1002495 Torx Screw for Wall Attachment
- 1 Quantity - **319618-8XL** U-Channel Bracket:
Use #1002499 Torx Screw for Panel Attachment
- 1 Quantity - **319618-6XL** Z-Bracket:
Use #1002499 Torx Screw for Panel Attachment
- 2 Quantity - **319618-7XL** Angle Bracket:
Use #1002499 Torx Screw for Panel Attachment

Front-Entry Corner Layout.



Alcove Closed Layout and Adjoining Front- Entry Stall.



STEP 3

INSTALL WALL BRACKETS

- A. Measure and mark the locations of centerlines for all the stiles and panels on walls.
- B. Using the wall brackets as templates, place bracket on wall and mark pilot holes. See **Installer's Note** for mounting height formula.
- C. Measure and mark the location of all mounting holes plumb, 3/4" (19mm) from panel center line; 7/8" (22mm) from stile centerline. **Fig. 3a. Note:** Orient bracket so hole pattern is staggered.
- D. Use #19 (.166) drill bit for 2" (50mm) deep pilot holes into adequate wall backing.
- E. Secure wall brackets with #1002495 screws.

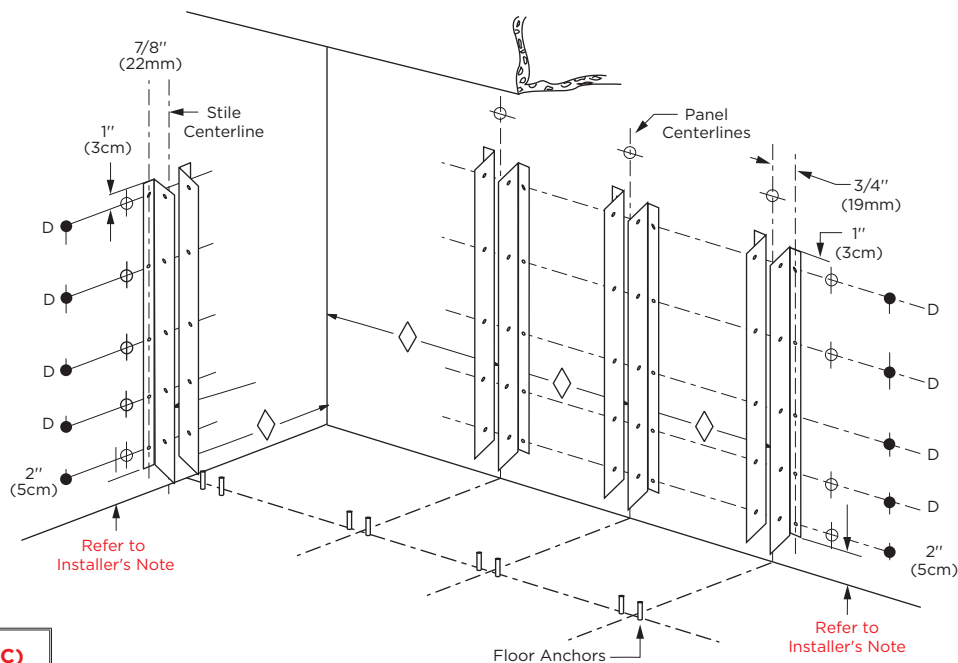
⊕ These mounting points require wall backing.

◇ Obtain dimension from Bobrick Layout Sheet

Caution: Panel centerline is not always on the stile centerline. Refer to Bobrick Layout Sheets for panel offsets.

Installer's Note: Bracket must be set center of panel. Use formula: $\text{Panel Height} - \text{Bracket Height} / 2 = \text{Offset}$. To identify the location of bracket, use formula: $\text{Offset} + \text{Floor Clearance Height} = \text{Bracket Height}$ measuring from floor to bottom of bracket.

Fig. 3a: Wall Bracket Layout



Floor Clearance (FC)
1" (2.5cm) AFF
4-1/2" (11cm) AFF
9" (23cm) AFF
12" (30cm) AFF

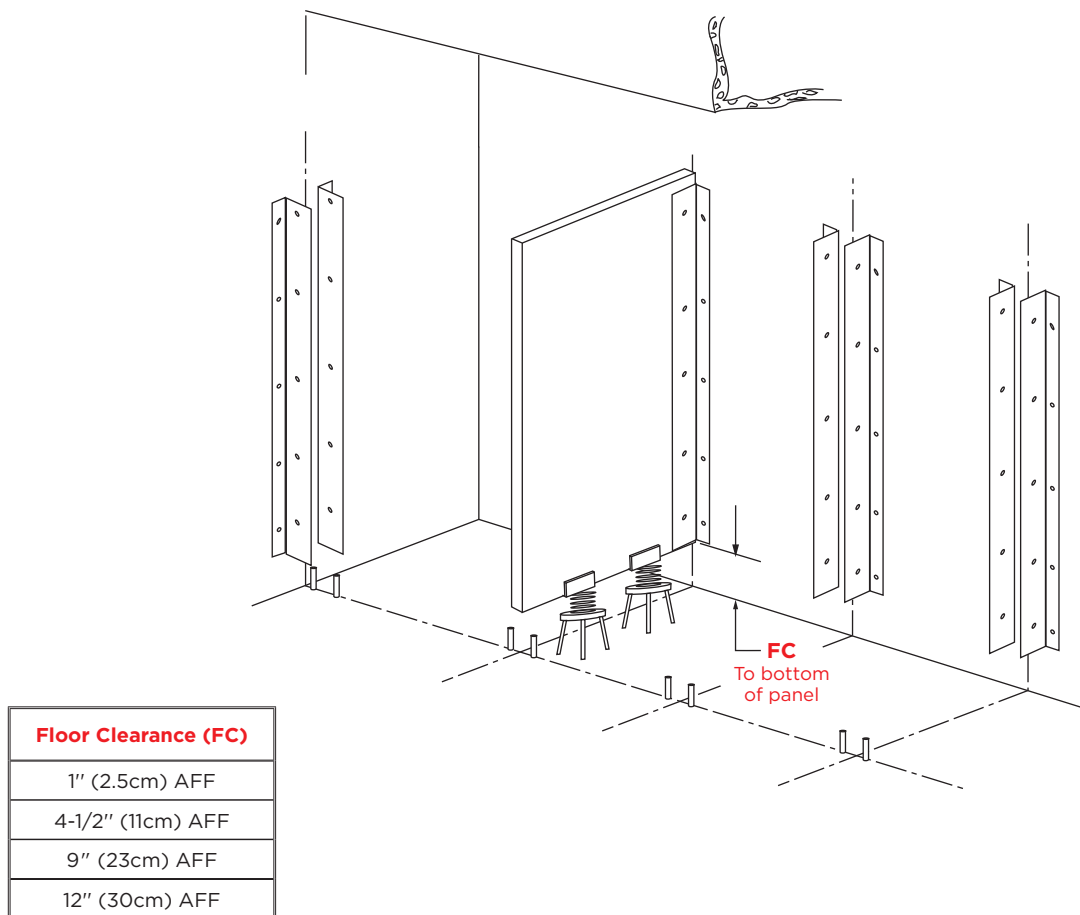
STEP 4

POSITION PANELS

- A. Place adjustable supports in position for each panel to hold them at the specified floor clearance.
- B. Place panels on the supports and into their respective wall brackets. Do not secure panels to wall brackets at this time.

Note: If the panel exceeds 60" (1524mm) the panel will be two pieces and require an H-Channel to obtain the panel height or an inline stile attached to the panel at the back wall will be provided to achieve the stall depth.

Fig. 4a: Panel and Adjustable Supports.



STEP 5

INSTALL STILE-TO-PANEL BRACKETS

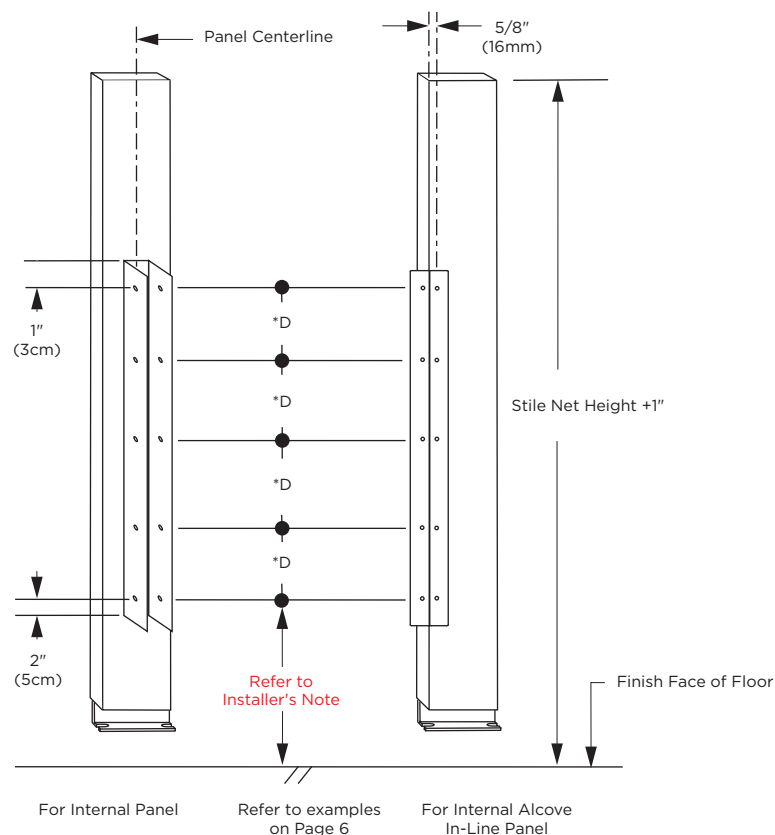
Caution: Panel centerline is not always on the stile centerline. Refer to Bobrick Layout Sheets for panel offsets.

- Measure and mark the centerlines for continuous U-channel bracket per stile. Using U-channel bracket as a template, mark the location of all mounting holes.
- For U-channel brackets attached to stiles, use a high-quality drill bit for 3/16" x 7/16" deep (4.7 x 11mm) pilot holes. Secure U-channel bracket to stile with #1002499 screws.
- For strip bracket, mark the location of all mounting holes 5/8" (16mm) from edge of stile following locations shown in diagram. Use a 3/16" x 7/16" deep (4.7 x 11mm) pilot hole in stile and panel. Secure strip bracket to panel and stile with #1002499 screws. **Do not drill through.**

Installer's Note: Bracket must be set center of panel. **Use formula: Panel Height - Bracket Height / 2 = Offset.**

To identify the location of bracket, use formula: **Offset + Floor Clearance Height = Bracket Height measuring from floor to bottom of bracket.**

Fig. 5a: Overhead-Braced Stiles.



Floor Clearance (FC)
1" (2.5cm) AFF
4-1/2" (11cm) AFF
9" (23cm) AFF
12" (30cm) AFF

For Internal Panel Refer to examples on Page 6 For Internal Alcove In-Line Panel

STEP 6

INSTALL STILES AND SET DOOR OPENINGS

- A. Place the stiles onto the threaded rods of anchors. Add a flat washer, lock washer, and a third hex nut to each threaded rod of floor anchors (these should already be in place on ceiling anchors—refer to Finished Detail of Floor Anchor diagram below). **Do not tighten hex nuts at this time.**
- B. Insure edge of panel is touching screw heads in brackets on stiles. Using brackets as templates, drill $3/16'' \times 7/16''$ (4.7 x 11mm) pilot holes in panel.
- C. Fasten brackets to panels with #1002499 screws.
- D. Use level to plumb stiles. Place shims between panels and wall.
- E. Set door openings to be square, plumb and true per Bobrick layout sheet.
- F. Tighten hex nuts on stile anchoring system.
- G. Secure panels to wall brackets using #1002499 screws.

Fig. 6a: Finished Detail of #1002701 Floor Anchor

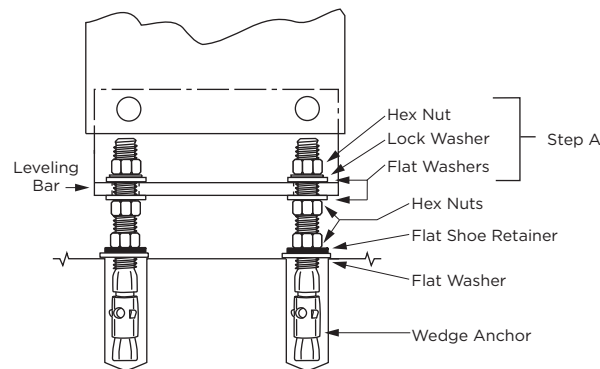
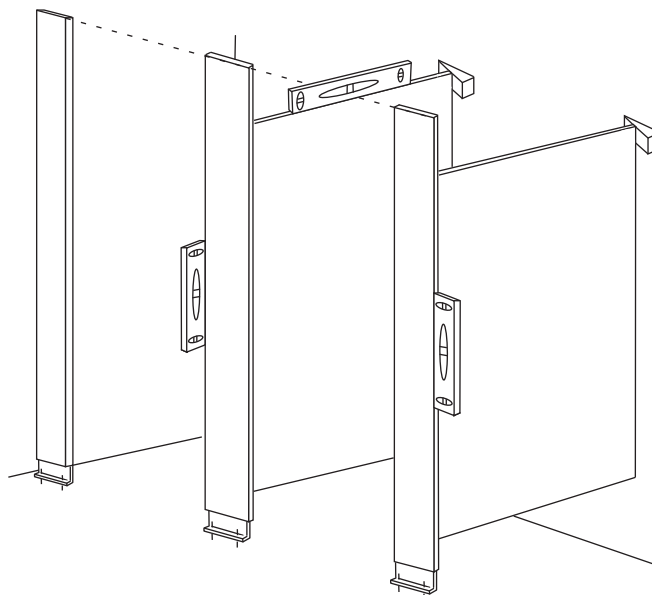


Fig. 6b: Overhead Braced Installation



STEP 7

INSTALL HEADRAIL (IF APPLICABLE)

Note: Bobrick provides headrail, #1002385, in 84" (2134mm) long sections. Headrail seams must be located over stiles.

- A. Measure wall-to-wall dimension less 1/4" (6mm). If it is a corner application, measure from wall to outside edge of stile less 1/8" (3mm).
- B. Place headrail over stile.
- C. For corner and alcove layouts, cut return headrail. Measure from the inside edge of front headrail to the back wall. **Fig. 7a** and **Fig. 7c**
- D. Using the headrail bracket as a template, mark the location for mounting holes in walls and headrails.
- E. Drill 3/16" x 3/4" (4.7 x 19mm) pilot holes into front headrail and stiles; then, at wall locations, drill #19 (.166) x 2" (50mm) pilot holes into adequate wall
- F. Fasten headrail bracket to front headrail with #1002499 screws and to wall with #1002495 screws.
- G. Connect the return headrail to front headrail with headrail bracket and four #1002499 screws.
- H. For corner layouts, install #1000978 end cap to finish the corner. Using the end cap as a template, mark and drill pilot hole, then secure end cap with one #1002499 screw.
- I. Fasten front headrail to stile by drilling pilot hole, then secure to stile with one #1002499 screw.

Optional Curtain Track:

- A. Cut curtain track to fit between stiles and fit inside of headrail.
- B. In the middle of and at 2" (50mm) from each end of the curtain track drill #25 (3.8mm) diameter holes through the curtain track and the headrail.
- C. Install curtain carrier hooks into curtain track.
- D. Fasten curtain track to headrail using #1000937 screws.
- E. Install shower curtain.

Fig. 7b: Curtain Track

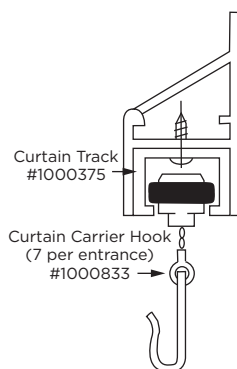


Fig. 7c: Alcove Configuration.

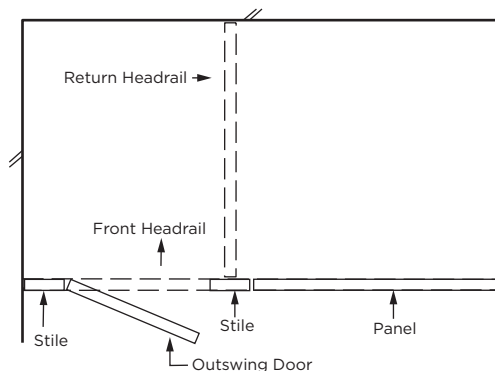


Fig. 7a: Headrail Installation Hardware - Corner Configuration

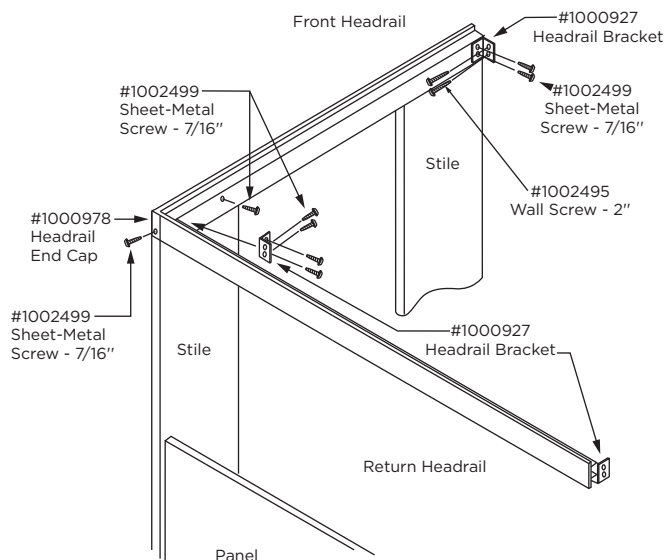
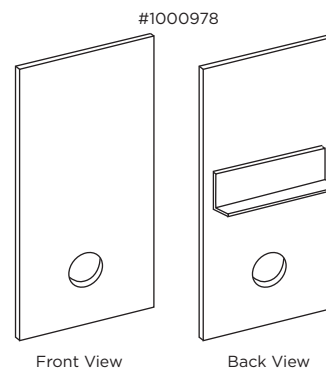


Fig. 7d: Detail of End Cap



STEP 8

INSTALL INSWING OR OUTSWING DOORS

- A. Using hinge diagram **Fig. 8c**, identify the three upper and one lower hinge set for right hand or left hand installation. Locate cam for the three upper hinges, #1002156.
- B. Separate hinge sets and fasten the four halves that have plastic bushings with “teeth” and cam alignment tabs onto stile using driver and #1002491 (1/4-20 x 1/2”) screws. Refer to diagram to ensure “J” and “L” halves are located properly.
- C. Fasten three upper hinge halves to door.
- D. Insert one hinge pin and one #1002156 plastic cam on each of the three upper stile hinge halves.
- E. Lift door and position onto the three upper stile hinge halves. Door should be hanging securely on upper three hinges.
- F. Insert remaining hinge pin in lower door and mount hinge half to door. Secure using #1002491 (1/4-20 x 1/2”) screws.

Note: Industry tolerance in the hardware will sometimes allow fine alignment adjustments to some partition components. These fine adjustments may be performed by loosening the hardware screws and adjusting the components the direction needed and re-tightening the screws.

To Increase or Decrease Opening of Door.

- A. Alignment tabs have been formed into the cam and plastic hinge bushing.
- B. Lift door to limit of upward travel (approximately 1/2” (13mm)). While door is lifted, raise cam above bottom bushing and rotate so alignment tabs meet. Ensure three upper hinges are set to same alignment tab.
- C. To set door in open position, rotate cams toward door opening direction.
- D. To set door in closed position, rotate cams toward door closing direction. Refer to Cam Setting diagram **Fig. 8d**.
- E. Door may not function properly if cam and bushing tabs on both hinges are not aligned properly.

Fig. 8a: Right-Hand Inswing Door

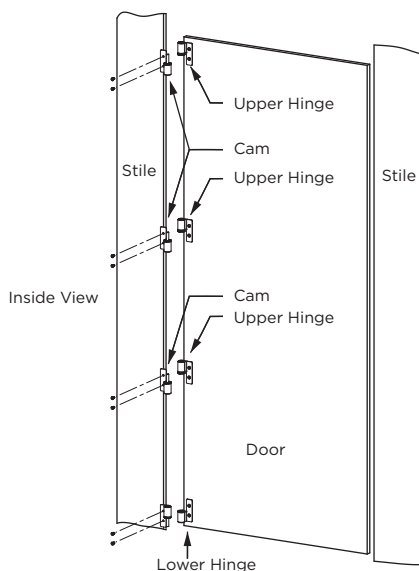


Fig. 8b: Right-Hand Outswing Door

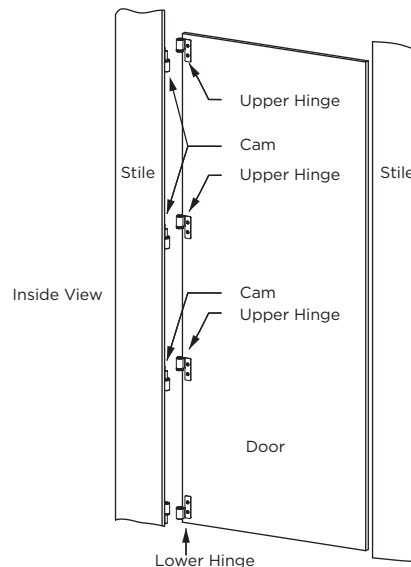


Fig. 8c: Inswing/Outswing Hinges Chart

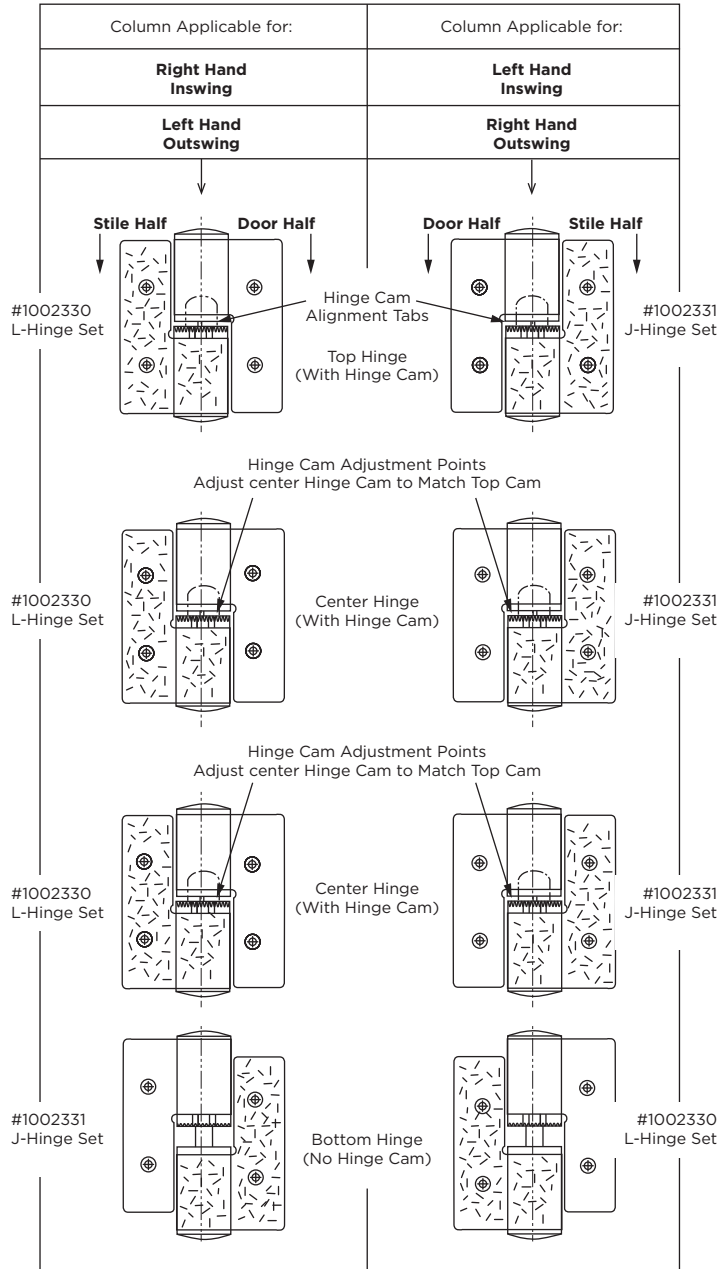
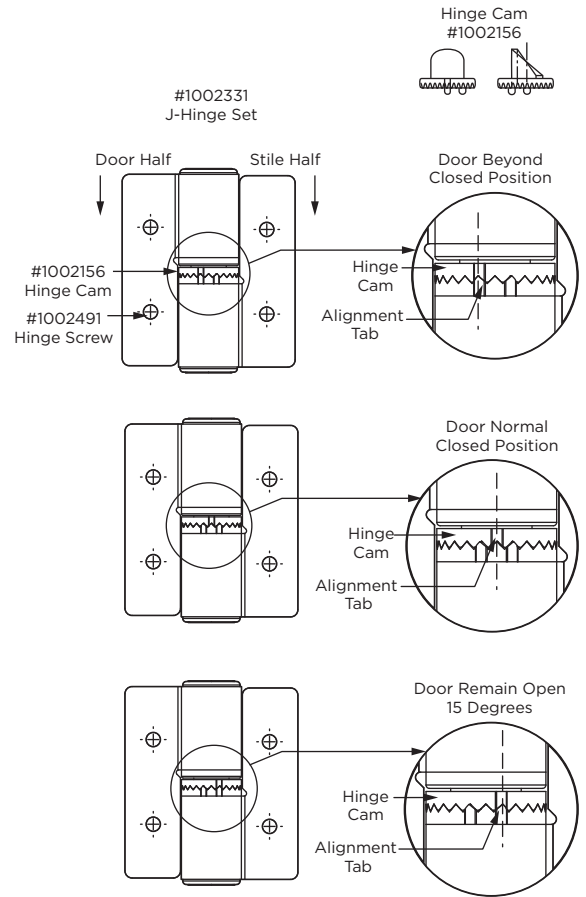


Fig. 8d: Cam Settings



#1002491
1/4-20 x 1/2" (M6-1 x 13mm)
Pin-Head Torx Screw

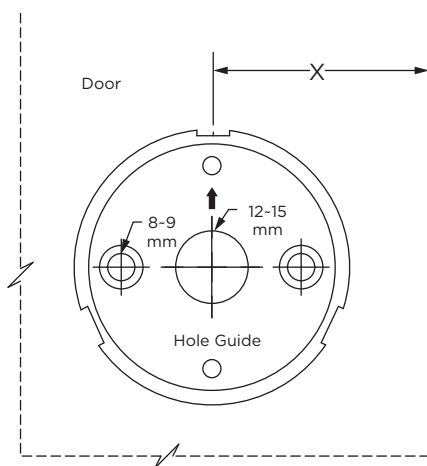
STEP 9

INSTALL OCCUPANCY INDICATOR LATCH AND KEEPER

- Use template and table below to locate mounting plate holes.
- Drill through center hole using 1/2" (13mm) drill bit.
- Drill through two outer holes using 5/16" or 23/64" (8 or 9mm) drill bit.
- Attach latch to door per **Fig. 9b** and **Fig. 9c**. Use two 1 3/16" (30mm) screws for 3/4" (19mm) thick doors. Use shorter indicator pin for 3/4" (19mm) material.
- Assure red indicator is showing in indicator window, when the latch track is fully engaged.

Note: Emergency Access -The latch allows the door to be opened from the exterior of the toilet compartment by inserting a 3mm Allen key into the keyhole in the center of the cover plate and turning the key to release the latch.

Fig. 9a: Occupancy Indicator Latch #10002612



Keeper

Keeper	X-Dimension
Inline I/S Keeper	1 11/16" (43mm)
Inline O/S Keeper	2 1/4" (57mm)
Alcove I/S Keeper	2 1/16" (52mm)
Alcove O/S Keeper	2 7/8" (73mm)

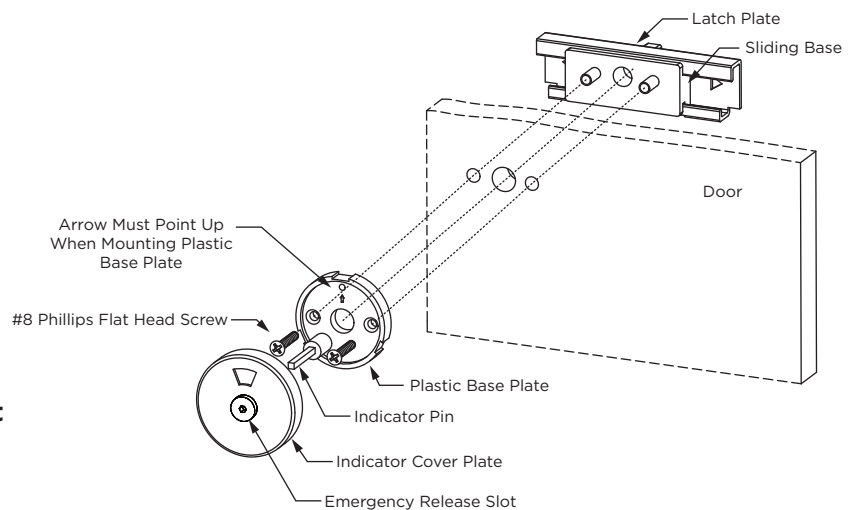
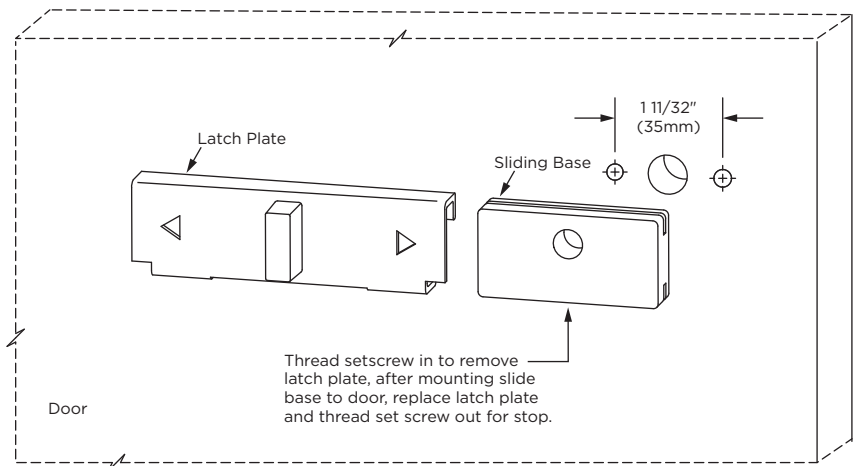


Fig. 9b: Occupancy Indicator Latch Packet

Fig. 9c: Latch Plate and Sliding Base



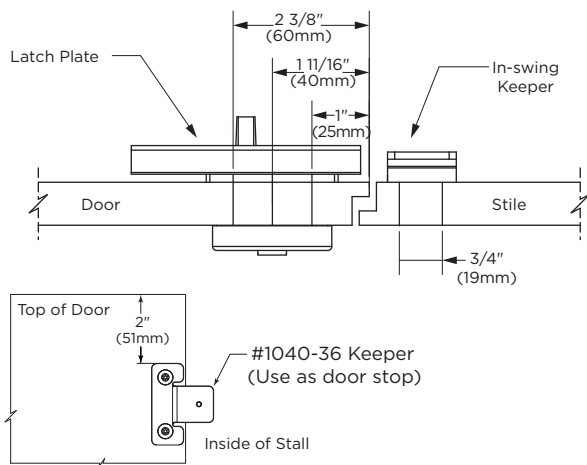
- F. Using the keeper as a template, attach keeper per **Fig. 9d, 9e, 9f, or 9g** on keeping stile (inside of stall).
- G. Mark and drill $7/16''$ (11mm) deep pilot hole using a $3/16''$ (4.7mm) drill bit. **Do not drill through.**
- H. Secure keeper to stile using #1002499 Pin-Head Torx Screw.

Note: All dimensions are based on a standard gap of $5/32''$ (4mm).

Pilot Hole Sizes: $3/16'' \times 7/16''$ (4.7 x 11mm) **Do not drill through.**

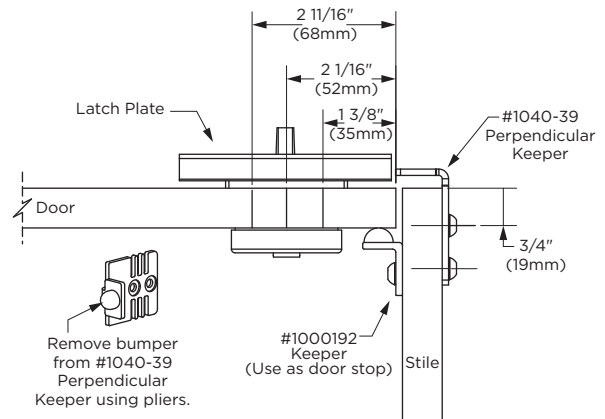


Fig. 9d: Inline Inswing



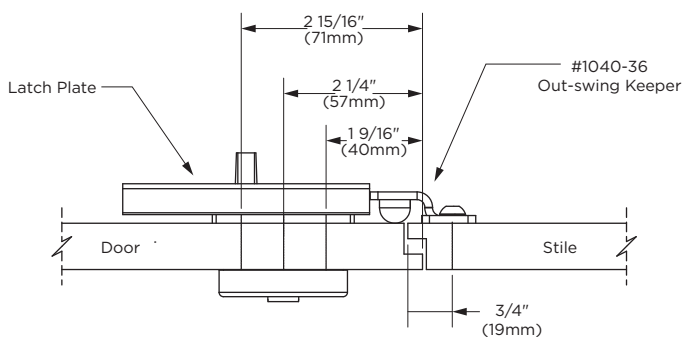
Use two #1002499 Pin-In-Head Torx screws to attach keeper.

Fig. 9e: Perpendicular/Alcove Inswing



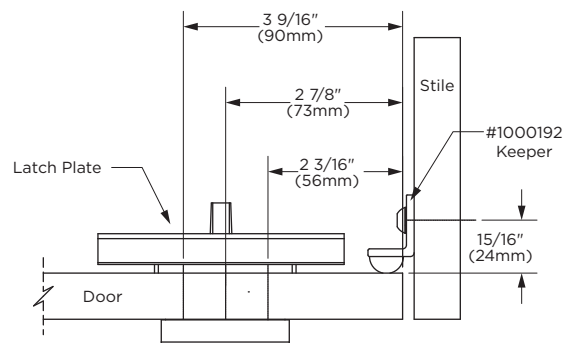
Use two #1002499 Pin-In-Head Torx screws to attach keeper.

Fig. 9f: Inline Outswing



Use two #1002499 Pin-In-Head Torx screws to attach keeper.

Fig. 9g: Perpendicular/Alcove Outswing

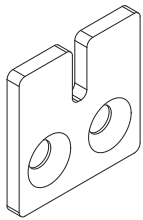


Use two #1002499 Pin-In-Head Torx screws to attach keeper.

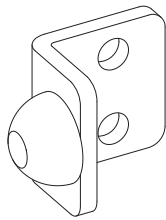
STEP 10**INSTALL WALL MOUNTED KEEPER (IF APPLICABLE)**

- Set the door to the closed position and verify the door is aligned with the other components, then slide the latch towards the wall.
- Select the appropriate wall mounted keeper (see **Fig. 10a - 10b**). Note: Inswing doors require #1000192 Alcove Keeper on opposite side of door to act as a door stop (see **Fig. 10a**).
- Position keeper on the wall and mark the mounting hole locations. Refer to diagram **Fig. 10a** for Inswing door or **Fig. 10b** for Outswing door.
- Drill pilot holes on marked locations using #19 x 2" (.166x50mm) drill bit.
- Attach the keeper to wall using #1002495 Pin-Head Torx Screw.

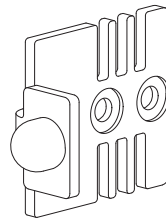
Pilot Hole Sizes: #19 x 2" (.166x50mm)



#1040-56
Wall Mounted Keeper
(Inswing Door)



#1000192
Alcove Keeper
(Use as Door Stop)



#1040-39
Perpendicular Keeper
(Outswing Door)



#1002495
#12 x 2" Pin-Head Torx Screw
(M5.5 x 50mm) Wall Screw

Fig. 10a: Inswing Door Wall Mount Keeper Installation Detail.

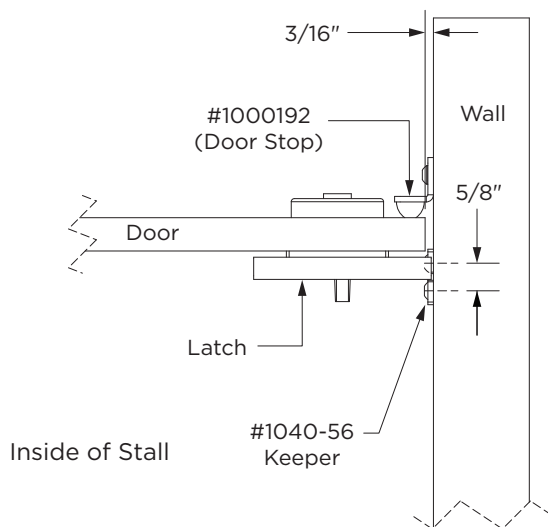
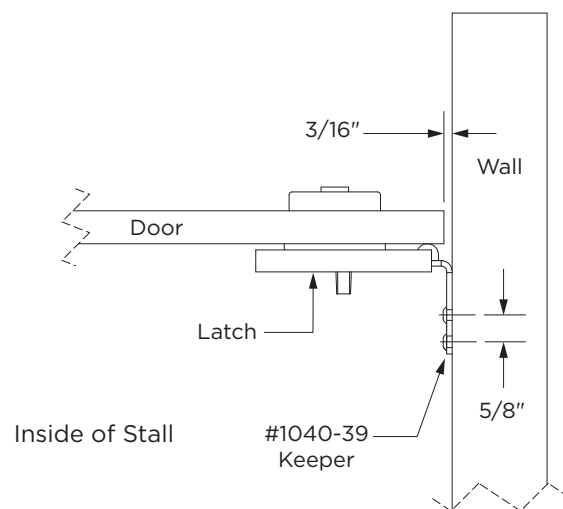
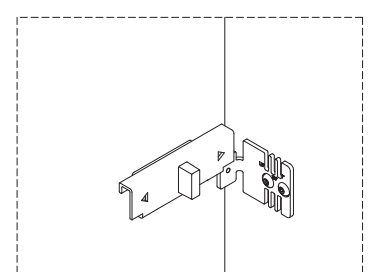
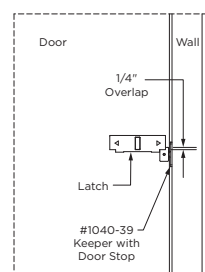
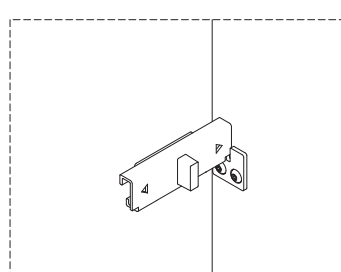
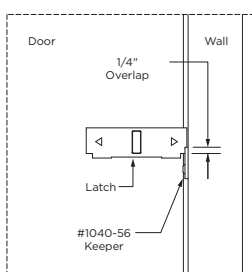


Fig. 10b: Outswing Door Wall Mount Keeper Installation Detail.



Note: Inswing doors require #1000192 Alcove Keeper on opposite side of door where the keeper is mounted to act as a door stop.



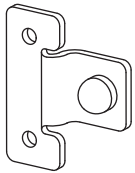
STEP 11

INSTALL DOOR STOP

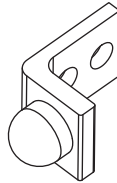
- A. For inline Inswing and inline outswing doors, attach two #1040-36 at the top and bottom of door.
- B. Mark and drill pilot hole. **Do not drill through.**
- C. Secure door stop to door with #1002499 Torx Screw.

Note: Door hinges and door stops should be on the same side of the door. Refer to **Fig. 11b** for Inswing door and **Fig. 11c** for Outswing door.

Pilot Hole Sizes: 3/16" x 7/16" (4.7 x 11mm) **Do not drill through.**



#1040-36
Outswing Keeper
(Use as Door Stop)



#1000192
Outswing Alcove Keeper
(Use as Door Stop)



#1002499
#12 x 7/16"
Pin-Head Torx Screw

Fig. 11a: Door Stop

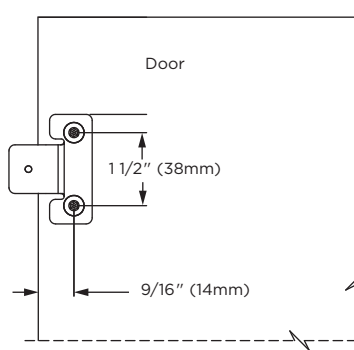


Fig. 11b: Inswing Door



Fig. 11c: Outswing Door



- A. For Perpendicular/Inswing doors, attach one #1000192 to stile to act as door stop. **Fig. 11d.**
- B. Mark and drill pilot hole. **Do not drill through.**
- C. Secure door stop to door with #1002499 Torx Screw.

Fig. 11d: Perpendicular/Inswing Door

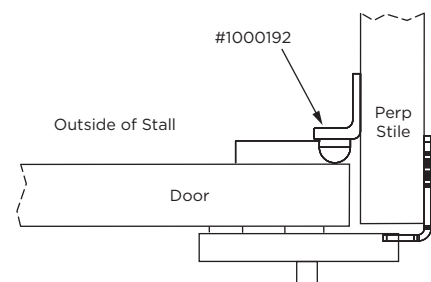
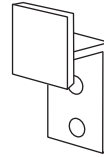
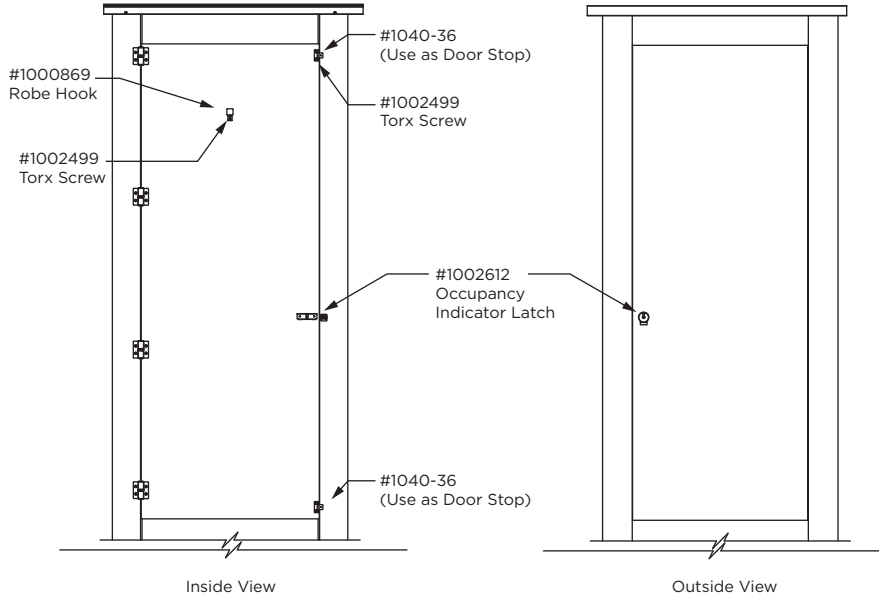


Fig. 12a: Inswing Door

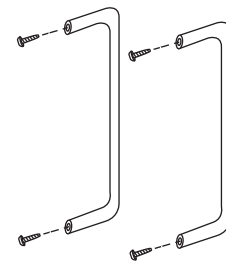
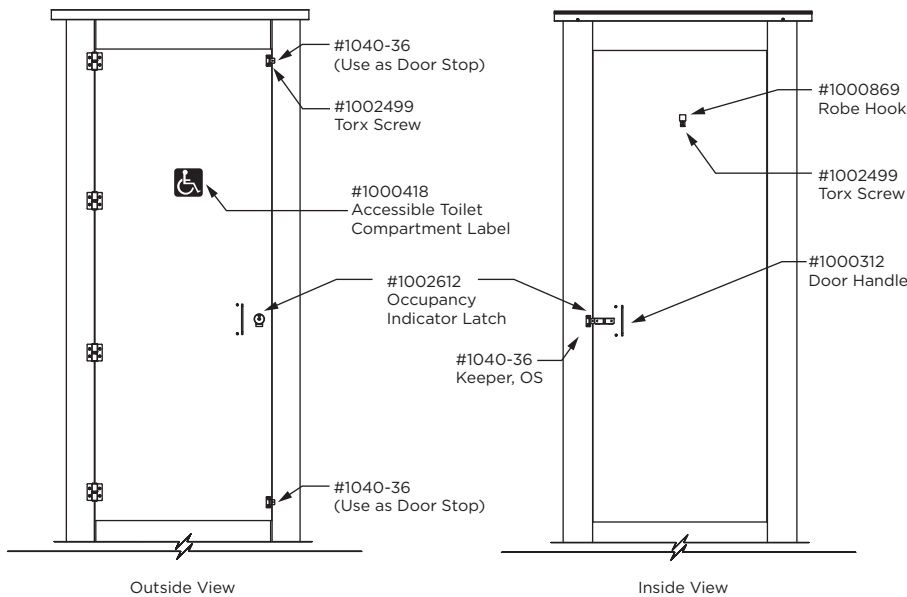


#1000869
Clothes Hook



#1000418
Accessible Toilet
Compartment Label

Fig. 12b: Outswing Door



#1000312
Door Handle Packet
(2 quantity)



#1002499
#12 x 7/16" Pin-Head Torx
Screw (M5.5 x 11mm)

STEP 13

INSTALL TRANSOM PANEL (IF APPLICABLE)

- A. Identify the cut length of strip bracket **Fig. 13a**
- B. Cut Strip Bracket #1001375 to size and remove sharp edges using a hand file.
- C. Mark pilot holes on bracket and drill-through using a 1/4" (6mm) drill bit. **Fig. 13b**
- D. Place strip bracket on the inside surface of the stile, mark the location of all mounting holes 5/8" (16mm) from edge of stile. **Fig. 13c**
- E. Drill 3/16" x 7/16" deep (4.7 x 11mm) pilot hole in stile. **Do not drill through.** Secure strip bracket to stile with #1002499 torx screws.
- F. Set door at the open position. Insert Transom Panel in between the stiles and into the headrail. **Fig. 13d**
- G. Use the strip bracket as a template. Drill 3/16" x 7/16" deep (4.7 x 11mm) pilot hole into Transom Panel. **Do not drill through.** Secure with #1002499 torx screws.
- H. Drill three 3/16" x 7/16" deep (4.7 x 11mm) pilot holes through headrail and into transom panel. Secure with #1002499 torx screws **Fig. 13e.**

Pilot Hole Sizes: 3/16" x 7/16" (4.7 x 11mm) Do not drill through.



Strip Bracket
Panel Inline with Stile



#1002499
#12 x 7/16" Pin-Head Torx
Screw (M5.5 x 11mm)



Transom Panel
3/4" (19mm) Thick Material

Fig. 13a: Installation Detail

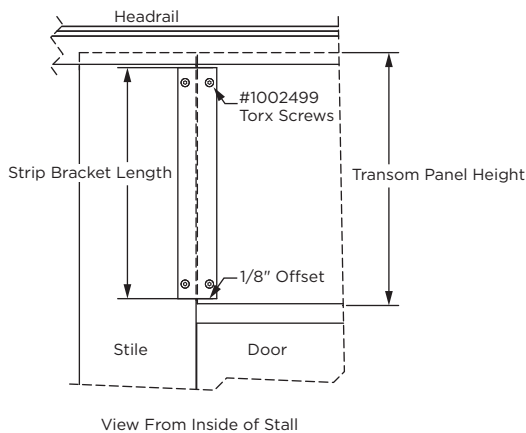


Fig. 13b: Pilot Hole Drilling Detail

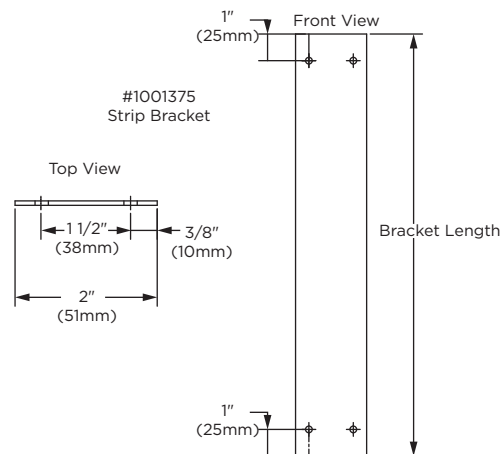


Fig. 13c

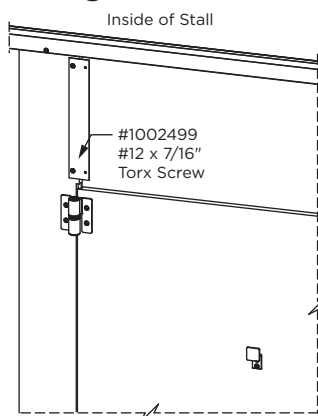


Fig. 13d

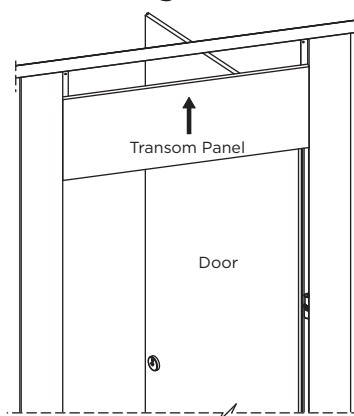
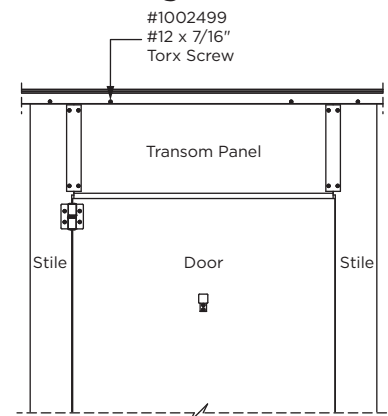


Fig. 13e



STEP 14

INSTALL SHOES

- A. Locate proper width shoe for stile.
- B. Confirm shoe retainer, #1002186, is installed on anchor bolt next to flat washer closest to floor or ceiling. For anchor assembly detail, reference diagram in **Step 2** of complete installation instruction sheet.
- C. Shoes accommodate 1" (25.4mm) thick or 3/4" (19mm) thick stiles. For 3/4" (19mm) thick stiles, orient shoe with 5/16" (8mm) wide flange return against faces and edge of stile.
- D. Standard Stile Installation - **Fig. 14a**. Open end of shoe and slide onto bottom of stile, trapping bottom flange under shoe retainer. Close open end of shoe, overlapping so holes are aligned. Install flat head retaining screw through double thickness of material to close shoe.
- D. Stile-to-Wall Installation - **Fig. 14b**. Stile-to-wall shoe retaining clip, #1002185, is supplied with every stile-to-wall. Locate shoe retaining clip. Hold retaining clip by its extended leaf with pliers. Spread shoe open at least one inch and insert retaining clip into hole on inner leaf of shoe until it snaps into place. Open end of shoe and slide onto bottom of stile, trapping bottom flange under shoe retainer. Shoe retaining clip will be positioned against wall. Close edges of shoe together until remaining hole snaps into place on retaining clip.
- E. Remove protective covering and wipe shoe clean.

Fig. 14a: Standard Stile Installation.

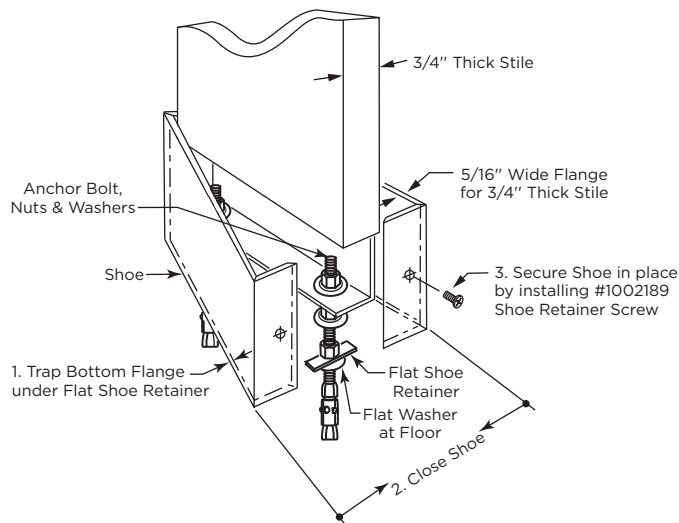
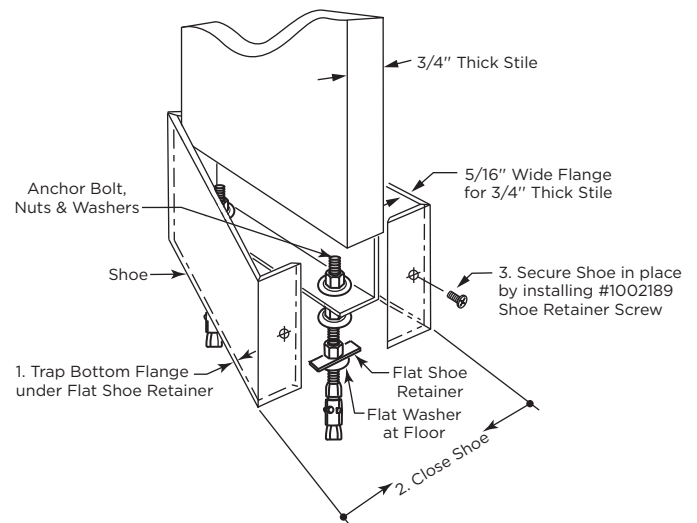


Fig. 14b: Stile-to-Wall Installation.



Replacement Shoe Guide

Stile Width	Bobrick Part Number	Stile Width	Bobrick Part Number
3" (76mm)	1002175	10" (254mm)	1002179
4" (102mm)	1002176	12" (305mm)	1002180
5" (127mm)	1002184	16" (406mm)	1002181
6" (152mm)	1002177	18" (457mm)	1002196
7" (178mm)	1002197	20" (508mm)	1002182
8" (203mm)	1002178	24" (610mm)	1002183

STEP 15

FINISH AND CLEANUP

- A. Remove any exposed labels from the components of toilet compartments.
- B. Clean surfaces as needed.

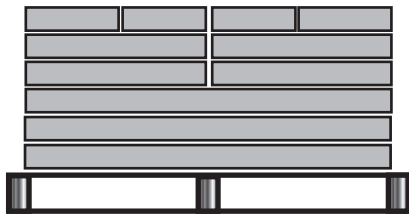
Caution: Do not use cleaners containing acid on Bobrick toilet compartments. For example, tile cleaners containing acid may attack the stainless steel hardware. For Bobrick recommendations, refer to Bobrick Form No. TB-21 and TB-60.

Important Toilet Partition Storage and Handling Information

Store in a clean, dry area. Do not store outside.
Move material to installation area 72 hours before installation.
Always store material flat with weight evenly supported.

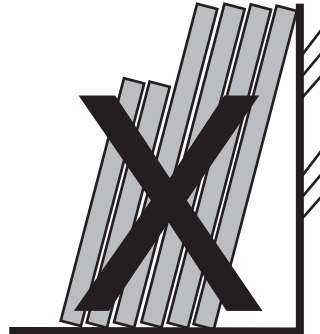
Toilet Partition Stacking

Do This



Stack Flat

Don't Do This



Stack Upright

Failure to follow these instructions may result in warped material which is not covered by Bobrick's warranty.



In the United States: BOBRICK WASHROOM EQUIPMENT, INC.

Los Angeles: 6901 Tujunga Ave., North Hollywood, CA 91605-6213; Tel: (818) 982-9600, FAX: (818) 503-1102
New York: 200 Commerce Drive, Clifton Park, NY 12065-1350; Tel: (518) 877-7444, FAX: (518) 877-5029,
or e-mail: customerservice@bobrick.com

In Canada: BOBRICK WASHROOM EQUIPMENT COMPANY

445 Rolark Drive, Scarborough, Ontario M1R 3B1 • Eastern Canada: Tel: (877) 423-6555 • FAX: (877) 423-8555
• Western Canada: Tel: (877) 423-6444 • FAX: (877) 423-8444

