

Advisory Bulletin

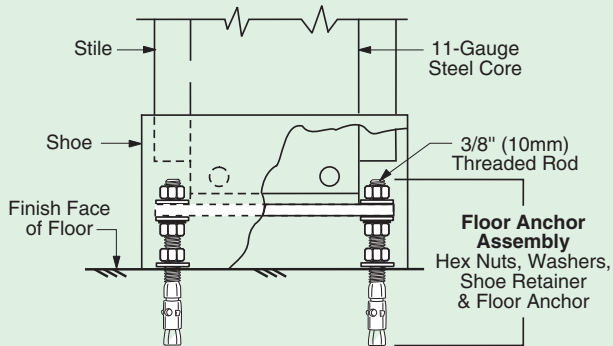

TB-46 Suggested Mounting Systems for Floor-Anchored and Overhead-Braced Toilet Partitions



LEVELING DEVICE

The steel-core reinforced stiles of Bobrick floor-anchored and overhead-braced toilet partitions are constructed with an 11-gauge steel core welded to a 3/8" thick leveling bar. Each floor anchor assembly includes a threaded rod (1), hex nuts (6), flat washers (3), lock washer (1). A four-inch (102mm) high stainless steel shoe is furnished to cover the leveling device after installation is completed.

Where floor-anchored toilet partitions are to be installed, the floor must provide proper support. Minimum 2-inch (51mm) penetration of wedge anchor into **minimum 3" (76mm) thick structural concrete** is required for an adequate support system (see Figure 1). Lightweight-concrete floors, structural-concrete floors less than 3" (76mm) thick, and plywood floors do not provide the strength required to support floor-anchored toilet partitions **unless they are reinforced** as shown below in Figures 2 and 3.

For **lightweight-concrete floors, structural-concrete floors less than 3" (76mm) thick, and plywood floors**, overhead-braced toilet partitions are required. Overhead-braced models require less floor strength than floor-anchored models because of the rigidity provided by the overhead bracing.

Floor anchors to accommodate wood floors will be provided if requested at time of order approval.

The actual mounting system design must be provided by the architect or structural engineer, and then furnished by others.

RECOMMENDED METHODS FOR ATTACHING TO FLOOR

FIGURE 1

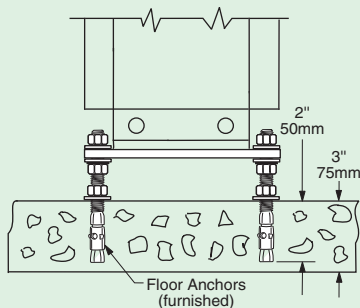

**STRUCTURAL CONCRETE FLOOR
3" (76MM) THICK OR MORE**

FIGURE 2

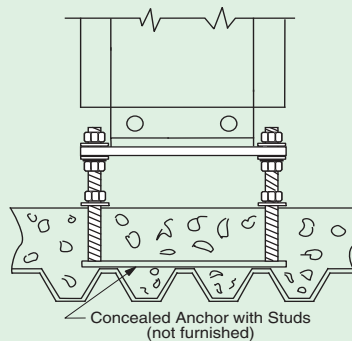

**CORRUGATED STEEL & LIGHT-
WEIGHT CONCRETE**

OR

**STRUCTURAL CONCRETE
LESS THAN 3" (76MM) THICK**

FIGURE 3

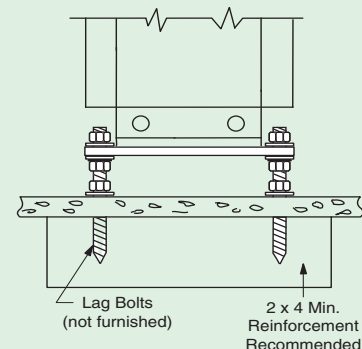

PLYWOOD FLOOR

continued . . .

Recommended Methods for Attaching to Wall

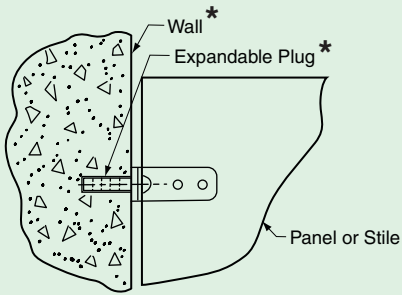

Masonry Wall

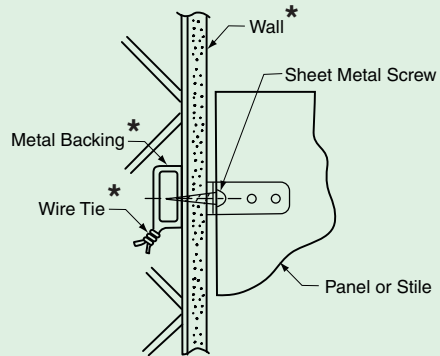

Sheet Metal Wall

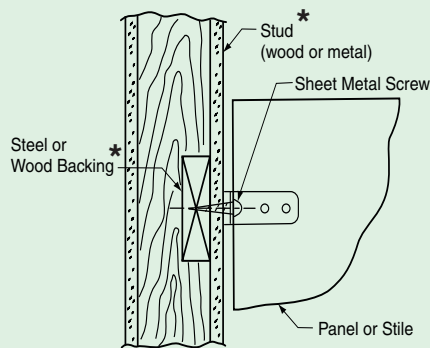

Stud Wall

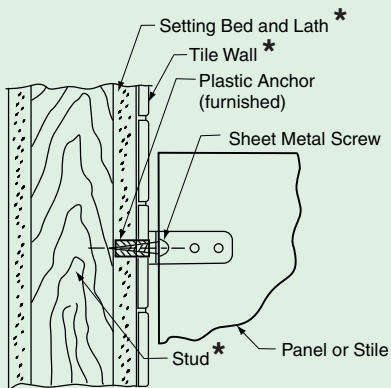

Tile Wall with Setting Bed

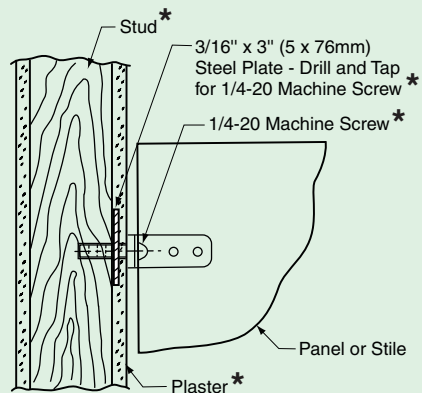

Plaster on Stud Wall

* Not Furnished by Bobrick