

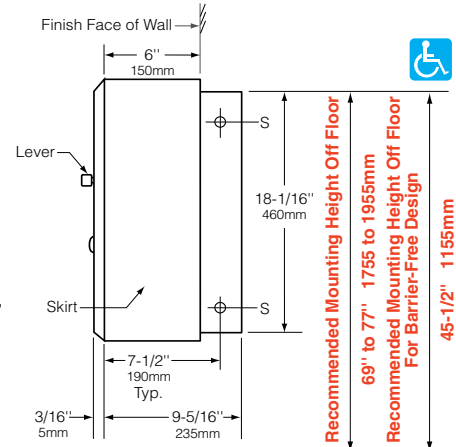

## Technical Data

# SEMI-RECESSED ROLL-PAPER-TOWEL DISPENSER

# B-38616

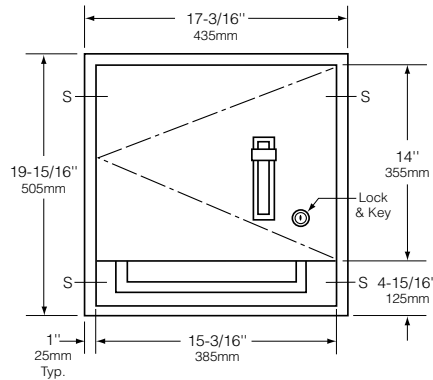
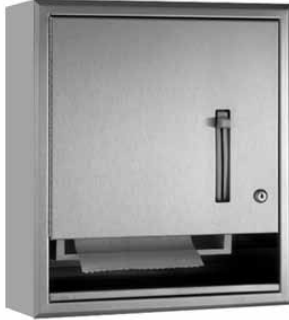

**Rough Wall Opening**  
 15-3/4" (400mm) wide  
 18-5/8" (475mm) high  
 3-1/2" (90mm) minimum  
 recessed depth

### MATERIALS:

**Cabinet** — 18-8 S, type-304 stainless steel. All-welded construction. Exposed surfaces have satin finish.

**Flange** — 18-8 S, type-304, 22-gauge (0.8mm) stainless steel with satin finish. Drawn and beveled, one-piece, seamless construction.

**Door** — 18-8 S, type-304, 18-gauge (1.2mm) stainless steel with satin finish. Secured to cabinet with a concealed, full-length stainless steel piano-hinge. Equipped with a stainless steel cable door-swing limiter and a tumbler lock keyed like other Bobrick washroom accessories.

**Skirt** — 18-8 S, type-304 stainless steel with satin finish.

**Roll-Paper-Towel Dispenser** — Enameled cold-rolled steel. Automatic roll-transfer system accepts one standard-core roll 8" (205mm) wide up to 800 ft (244 m) long and one stub roll up to 4" (100mm) diameter. Lever-operated unit is adjustable to dispense 2-1/2", 4", or 5" (65, 100, or 125mm) preset lengths of towel per stroke.

### OPERATION:

Building operator controls rate of use by selecting length of paper towel fed per stroke of lever. Automatic roll-transfer system uses up stub roll before new roll starts to dispense; eliminates towel outages and reduces maintenance time. Cable door-swing limiter prevents damage to washroom accessories and walls. Lever is operable with one hand, without tight grasping, pinching, or twisting of the wrist and with less than 5 pounds of force (22.2 N) to comply with barrier-free accessibility guidelines (including ADAAG in U.S.A.).

### INSTALLATION:

Provide framed rough wall opening 15-3/4" wide x 18-5/8" high (400 x 475mm). Minimum recessed depth required to finish face of wall is 3-1/2" (90mm). Allow clearance for construction features that may protrude into rough wall opening. Coordinate with mechanical engineer to avoid pipes, vents, and conduits. Mount unit in rough wall opening with shims between framing and cabinet at all points indicated by an S, then secure unit with sheet-metal screws furnished by manufacturer.

### SPECIFICATION:

Semi-recessed roll-paper-towel dispenser shall be type-304 stainless steel with all-welded construction; exposed surfaces shall have satin finish. Flange shall be drawn and beveled, one-piece, seamless construction. Door shall be secured to cabinet with a concealed, full-length stainless steel piano-hinge and equipped with a stainless steel cable door-swing limiter and tumbler lock keyed like other Bobrick washroom accessories. Roll-paper-towel mechanism shall be adjustable to dispense preset lengths of towel from standard-core rolls. Automatic roll-transfer system shall dispense towels from stub roll before new roll starts to dispense. Lever shall be operable with one hand and with less than 5 pounds of force (22.2 N) to comply with barrier-free accessibility guidelines (including ADAAG in U.S.A.). Manufacturer's service and parts manual shall be provided to the building owner/manager upon completion of project.

**Semi-Recessed Roll-Paper-Towel Dispenser shall be Model B-38616 of Bobrick Washroom Equipment, Inc., Clifton Park, New York; Jackson, Tennessee; Los Angeles, California; Bobrick Washroom Equipment Company, Scarborough, Ontario; Bobrick Washroom Equipment Pty. Ltd., Australia; and Bobrick Washroom Equipment Limited, United Kingdom.**