

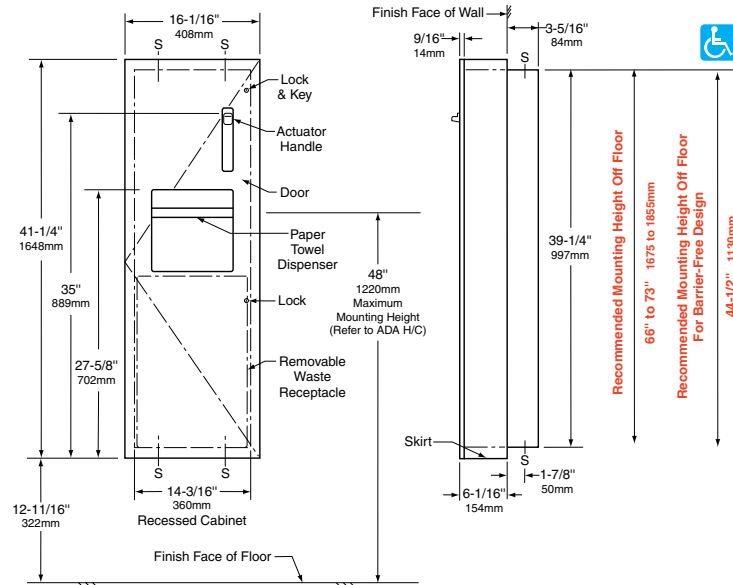

Technical Data

TrimLineSeries™ SEMI-RECESSED ROLL TOWEL DISPENSER AND WASTE RECEPTACLE

B-396034



Rough Wall Opening
 14-1/2" (368mm) wide
 39-3/4" (1010mm) high
 3-9/16" (90mm) minimum
 recessed depth

MATERIALS:

Cabinet & Flange — 18-8 S, type-304, heavy-gauge stainless steel. All-welded construction. Exposed surfaces have satin-finish.

Skirt — 18-8 S, type-304, 22-gauge (0.8mm) stainless steel with satin-finish.

Door — 18-8 S, type-304, 18-gauge (1.2mm) stainless steel with satin-finish. 9/16" (14mm) 90° return for maximum rigidity. Secured to cabinet with a concealed, full-length stainless steel piano-hinge. Equipped with a stainless steel cable door-swing limiter and two tumbler locks keyed like other Bobrick washroom accessories.

Skirt — 18-8 S, type-304, 22-gauge (0.8mm) stainless steel with satin-finish.

Roll-Paper-Towel Dispenser — Enameled cold-rolled steel.

Waste Container — Removable, leak-proof, rigid molded plastic. Capacity: 8.6-gal. (32.6-L).

OPERATION:

Roll-paper-towel dispenser delivers preset length of towel: 2-1/2", 4" or 5" (65, 100 or 125mm) per stroke of lever. Accepts standard-core rolls 8" (205mm) wide, 800 feet (244 m) long. Automatic towel transfer eliminates paper towel outages and stub roll waste. Unit accepts a stub roll up to 4" (100mm) diameter, together with a new roll. When stub roll is used up, new roll automatically starts to dispense. Dispenser lever is operable with one hand, without tight grasping, pinching, or twisting of the wrist, and with less than 5 pounds of force (22.2 N) to comply with barrier-free accessibility guidelines (including ADAAG in U.S.A.). Waste receptacle is emptied by unlocking door with key provided and removing plastic container. Door conceals flange from view. Cable door-swing limiter prevents damage to washroom accessories and walls.

INSTALLATION:

Provide framed rough wall opening 14-1/2" wide x 39-3/4" high (368 x 1010mm). Minimum recessed depth required to finish face of wall is 3-9/16" (90mm). Allow clearance for construction features that may protrude into opening from opposite wall. Coordinate with mechanical engineer to avoid pipes, vents, and conduits. Mount cabinet with shims between framing and cabinet at all points indicated by an S, then secure unit with #8 x 1-1/4" (4.2 x 32mm) sheet-metal screws (not furnished).

SPECIFICATION:

Semi-recessed roll towel dispenser and waste receptacle shall be type-304 stainless steel with all-welded construction; exposed surfaces shall have satin finish. Door shall be 18 gauge (1.2mm); have 9/16" (14mm) 90° return; be secured to cabinet with a concealed, full-length stainless steel piano-hinge; and equipped with a stainless steel cable door-swing limiter and two tumbler locks keyed like other Bobrick washroom accessories. Towel mechanism shall be adjustable to dispense preset lengths of paper towels from standard-core rolls 8" (205mm) wide and shall feature automatic towel transfer that dispenses stub roll before starting new 800-ft (244 m) long roll. Dispenser lever is operable with one hand and with less than 5 pounds of force (22.2 N) to comply with barrier-free accessibility guidelines (including ADAAG in U.S.A.). Waste receptacle shall be furnished with removable, leak-proof, rigid molded plastic waste-container with a minimum capacity of 8.6-gal. (32.6-L). Manufacturer's service and parts manual shall be provided to the building owner/manager upon request.

Semi-Recessed Roll Towel Dispenser And Waste Receptacle shall be Model B-396034 of Bobrick Washroom Equipment, Inc., Clifton Park, New York; Jackson, Tennessee; Los Angeles, California; Bobrick Washroom Equipment Company, Scarborough, Ontario; Bobrick Washroom Equipment Pty. Ltd., Australia; and Bobrick Washroom Equipment Limited, United Kingdom.