

INSTRUCTIONS FOR INSTALLATION AND MAINTENANCE

BOBRICK MODEL B-306 RECESSED SOAP DISPENSER

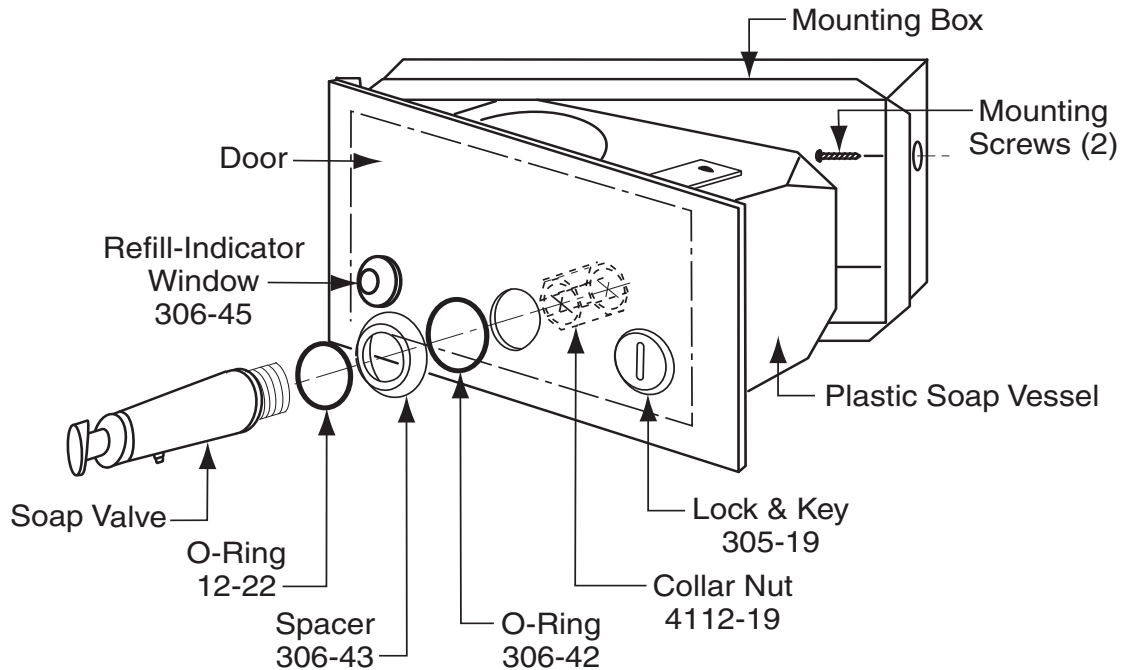

TO INSTALL UNIT:

1. Mount unit so the spout of soap valve is over a sink or lavatory.
2. Door is secured to left side of mounting box (facing unit) with a full-length hinge. Unlock unit with key provided and pull toward you to open the door.
3. Place mounting box in rough wall opening and secure to framing with two mounting screws provided.
4. Close door and lock in place with key provided.

Rough Wall Opening
 8-3/8" (210mm) wide
 4-3/8" (110mm) high
 3-7/8" (100mm) minimum
 recessed depth

TO FILL SOAP VESSEL:

1. Unlock unit with key provided and pull toward you to open the door.

Note: It is not necessary to remove the door and soap vessel from mounting box for refilling. For additional maintenance and cleaning purposes, the soap vessel may be removed from the door by removing the collar nuts from the soap valve and window. The pop rivet also needs to be removed from the vessel.

2. Fill soap vessel to desired level with commercially marketed all-purpose hand soaps.
3. Close door and lock in place with key provided.

REPLACEMENT PARTS LIST

Part Name	Part No.
Lock & Key	305-19
Red Lid for Soap Vessel	305-127
Spacer Replacement Packet	306-73
Refill-Indicator Window with Nut	306-35
Liquid Soap Valve & Collar Nut	306-476



In the U.S.A.: BOBRICK WASHROOM EQUIPMENT, INC.

200 Commerce Drive, Clifton Park, New York 12065-1350 • Tel: (518) 877-7444 • FAX: 518-877-5029
 11611 Hart Street, North Hollywood, California 91605-5882 • Tel: (818) 982-9600 • FAX: 818-503-1102

In Canada: BOBRICK WASHROOM EQUIPMENT COMPANY

45 Rolark Drive, Scarborough, Ontario M1R 3B1 • Tel: Ontario East (877) 423-6555, FAX: (877) 423-8555
 • Tel: Manitoba West (877) 423-6444, FAX: (877) 423-8444