

# INSTRUCTIONS FOR INSTALLATION AND MAINTENANCE

## BOBRICK NAPKIN AND TAMPON VENDORS, (SERIES F)

### MODELS B-282 AND B-352

#### REPLACEMENT PARTS LIST

Part Name	Part No.
Dual Mechanism 25c	282-213
Napkin Mechanism 25c	282-223
Tampon Mechanism 25c	282-227
Tampon Rotor	352-15
Key for Door	330-43
Napkin Coin Label 25c	352-110N
Tampon Coin Label 25c	352-110T
Lock & Key for Coin Box	352-111
Key for Coin Box	352-112
Napkin Weight	352-113
Mechanism Handle with Setscrew	282-114
Coin Box Cover with Lock & Key	352-203
Tampon Weight	352-314

#### Recommended Mounting Height Off Floor

74" to 78" (1880 to 1981mm)  
to top of rough wall opening  
For barrier-free design 60-1/2" (1537mm)

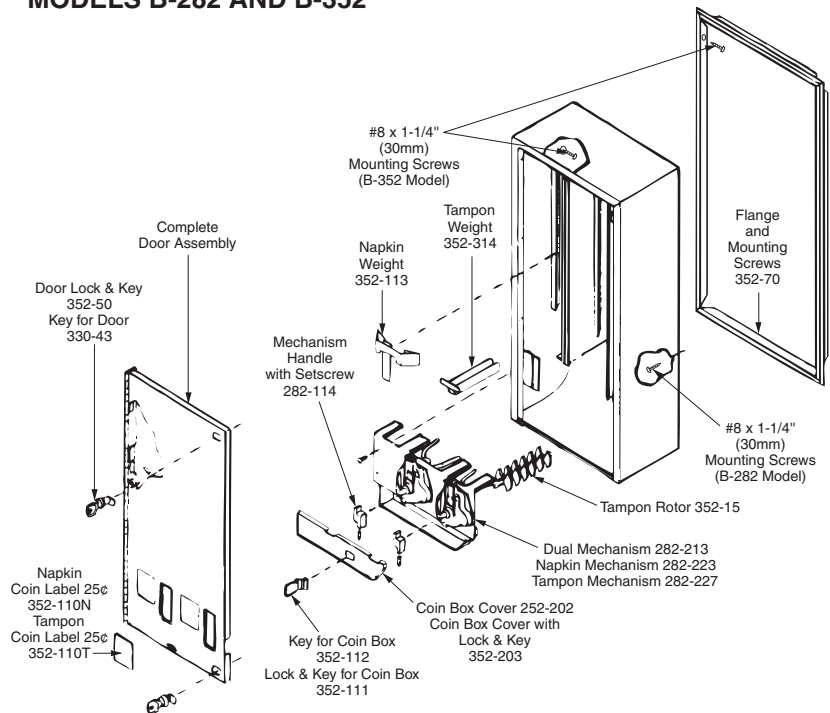

Model B-352 Shown

#### INSTALLATION:

##### Surface-Mounted Model B-282 Only

Secure vendor to wood studs or metal wall with four #8 x 1-1/4" (30mm) pan-head sheet-metal screws furnished, through mounting holes in back of cabinet. For solid walls, use #8 fiber plugs or 1/8" (3mm) expansion bolts. For hollow walls, use anchor nuts with machine screws.

##### Recessed Model B-352 Only

1. Remove flange (Part No. 352-70) from vendor and insert flange into front of rough wall opening. NOTE: If necessary, place wooden shims at screw holes between flange and rough wall opening to prevent distortion of flange.

2. Secure flange to side framing of rough wall opening with four #8 x 1-1/4" (30mm) flat head sheet metal screws furnished, *making certain screw heads do not project above countersunk holes.*

3. Insert vendor into rough wall opening until vendor fills depth of rough wall opening or until face of vendor is flush with flange.

4. Secure vendor to framing of rough wall opening with four #8 x 1-1/4" (30mm) flat-head sheet-metal screws furnished, through mounting holes located in top and bottom of vendor cabinet. NOTE: If necessary, place wooden shims at screw holes between cabinet and framing to prevent distortion of cabinet.

#### MAINTENANCE:

##### To Load Napkins

1. Remove weight (Part No. 352-113) from the center track of vendor.
2. Insert 15 napkin packages, measuring between 2-7/8" x 3/4" to 3-1/8" x 1-1/8" x 4-3/8" maximum (73 x 19 x 105 to 80 x 29 x 111mm) into each channel. These include Kotex 707, Guards No. 147, Pure-Nap No. 606-M4, and Modess No. 4 (see Bobrick Advisory Bulletin TB-25).
3. Replace weight on top of napkins in both channels by sliding over the center track.

##### To Load Tampons

1. Remove weight (Part No. 352-314) from single channel at right side of vendor.
2. Insert 27 tampons, measuring between 4-5/8" long x 9/16" diameter minimum to 5-1/8" long x 3/4" diameter maximum (118 x 14 to 130 x 19mm) into single channel. These include Kotex No. 1462, Tampax, and Meds.
3. Replace weight on top of tampons by sliding over tampon track.

##### To Dispense Napkin or Tampon

1. Insert coin in coin slot, turn handle clockwise as far as it will go and release.
2. When *all* napkins or tampons have been dispensed, the napkin weight or tampon weight actuates the *empty* indicator which blocks the coin slot and prevents another coin from being inserted.

##### If Vendor Fails to Work Properly, make sure that:

1. Machine is loaded with correct size napkins and tampons.
2. Damaged napkins or tampons are not jamming mechanism.
3. Weights are in place on top of napkins and tampons.
4. Napkin support plates (the 4" (100mm) fingers that napkin boxes rest on) are in straight, horizontal position.
5. Tampon rotor (Part No. 352-15) is properly installed with the round shaft inserted in the slot, with pocket rotor in *up* position.
6. Coin box is not full.

##### To Replace Complete Dual Mechanism

1. Order complete dual mechanisms for 25c coin denomination.
2. Remove napkins, tampons, and weights from vendor.
3. Remove complete dual mechanism by unscrewing four #8-32 x 1/4" (6mm) pan-head screws.
4. Install new complete dual mechanism with the same screws.
5. Install new coin plates by removing paper backing and applying with pressure, if replacing.

##### To Replace Individual Napkin and Tampon Mechanisms

1. Order individual napkin or tampon mechanisms for 25c coin denomination.
2. Full instructions for replacement of individual napkin and tampon mechanisms will be included with shipment.

##### To Remove Door

1. Unlock and open door.
2. Use nail or similar object to push hinge pin out of hinge knuckle and use pliers to pull hinge pin out.



#### In the U.S.A.: BOBRICK WASHROOM EQUIPMENT, INC.

200 Commerce Drive, Clifton Park, New York 12065-1350 • Tel: (518) 877-7444 • FAX: 518-877-5029  
11611 Hart Street, North Hollywood, California 91605-5882 • Tel: (818) 982-9600 • FAX: 818-503-1102

#### In Canada: BOBRICK WASHROOM EQUIPMENT COMPANY

45 Rolark Drive, Scarborough, Ontario M1R 3B1 • Tel: Ontario East (877) 423-6555, FAX: (877) 423-8555  
• Tel: Manitoba West (877) 423-6444, FAX: (877) 423-8444