

INSTALLATION INSTRUCTIONS

BOBRICK SHOWER SEAT MODELS B-517 AND 518

Figure 1

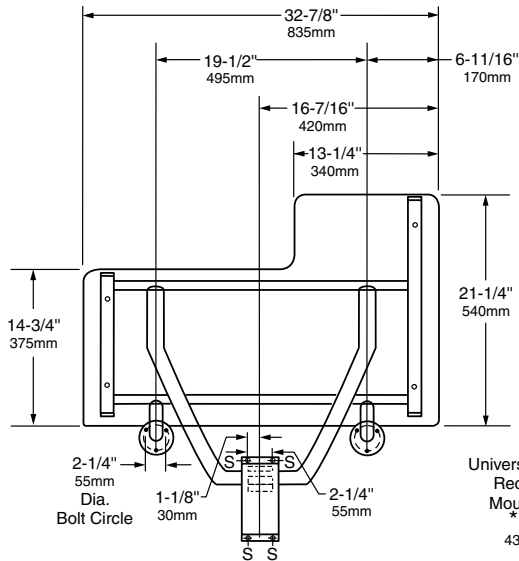
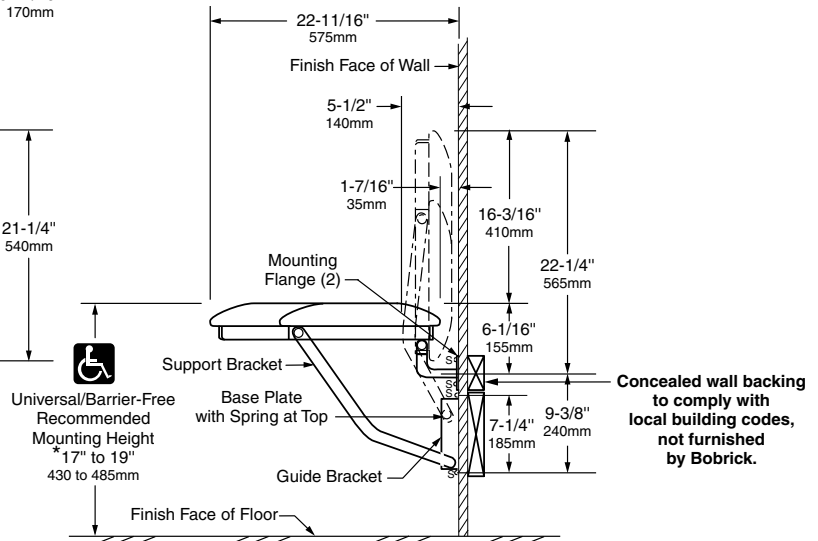

Figure 2



Left-Hand Seat Shown

*Consult local building codes

Installation to Wall. Secure unit to wall at points indicated by an S, with the two Mounting Flanges located at top and the Baseplate and Guide Bracket below. The bottom of the Support Tube must be positioned within the Baseplate and Guide Bracket before they are secured to wall. * Mounting height of shower seat must comply with local building codes.

1. Install Mounting Flanges to Wall.

- A. Locate seat horizontally on wall to comply with local building codes.
- B. Use Mounting Flanges as templates to mark holes.
 - 1) Check to make sure seat surface is horizontal and Mounting Flanges are flat against wall.
 - 2) Make sure holes marked for Mounting Flanges align with wall backing.
- C. Drill holes for Mounting Flange fasteners and secure Mounting Flanges to wall with appropriate fasteners.
- D. Check to see if seat moves freely from horizontal to vertical position.

IMPORTANT NOTES

- 1) **For stud wall construction,** install backing (not furnished by Bobrick) (see Figure 2). Backing must be provided before the finished shower wall is applied. Secure with #14 x 2-1/2" (6.3 x 65mm) stainless steel mounting screws furnished by manufacturer.
- 2) **For prefabricated shower stalls,** adequate backing must be provided by the shower stall manufacturer (see Figure 2). Secure with #14 x 2-1/2" (6.3 x 65mm) stainless steel mounting screws furnished by manufacturer.
- 3) **For concrete walls,** provide fiber plugs or expansion shields for use with furnished screws, or provide 1/4" (6mm) toggle bolts or expansion bolts. Wall anchors not furnished by Bobrick.

CAUTION: This shower seat is no stronger than the anchors and walls to which it is attached and, therefore, must be firmly secured in order to support the loads for which it is intended. Consult and comply with local building codes.

2. Install Baseplate with Spring and Guide Bracket to Wall.

- A. Support seat in level horizontal position.
- B. Locate Guide Bracket on wall with bottom center of Support Tube resting on bottom of Guide Bracket (see Figure 2).
- C. Mark holes on wall using Guide Bracket as a template.
- D. Drill holes in wall for appropriate fasteners (see Figure 3). Install fasteners.
- E. Place Baseplate on wall with curled spring at top aligning holes in Baseplate with fasteners.
- F. Place Guide Bracket over Support Tube and fasten to wall.

continued . . .

3. Test Installation.

- A. Raise and lower seat to make sure seat moves freely.
- B. When seat is raised parallel to the wall, it will remain in this position until lowered (see Figure 2).
- C. Examine seat, fasteners, Mounting Flanges, Baseplate, and Guide Bracket to make sure there are no loose fastenings.

OPERATION:

Shower seat folds up against wall when not in use. The spring at the top of the Baseplate holds seat in upright position until released by pulling the top of the seat away from the wall. Mounting Flanges and Guide Bracket allow for varying mounting heights and leave the floor clear for easy cleaning. Bobrick shower seats, when properly installed, have sufficient strength to support 400 lbs, complying with barrier-free accessibility guidelines (including ADAAG in U.S.A.).

Figure 3

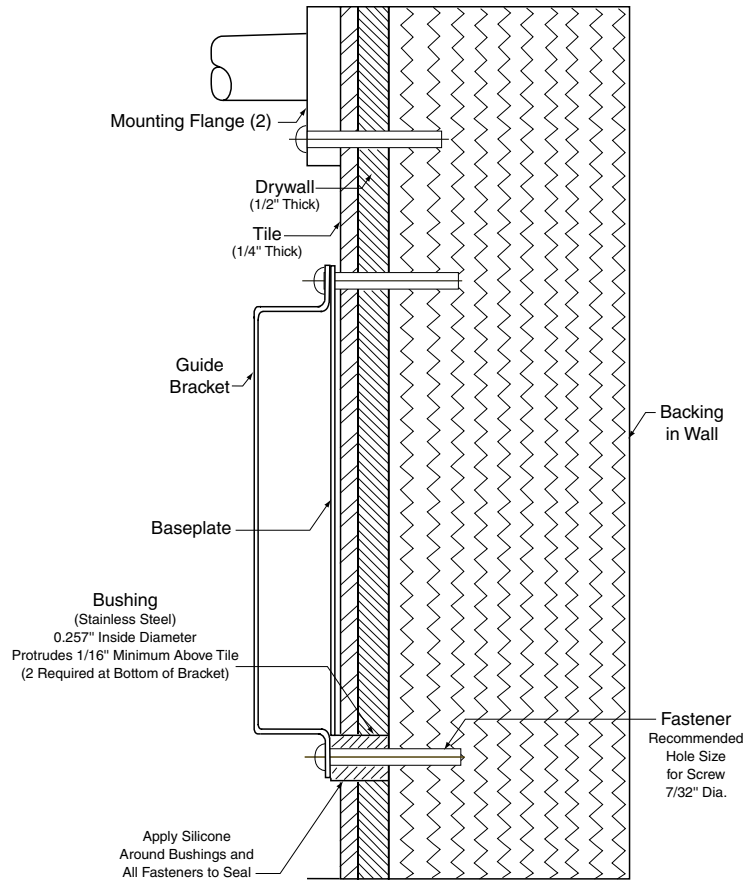

NOTE: Bushings (2) are not furnished by manufacturer.



In the U.S.A.: BOBRICK WASHROOM EQUIPMENT, INC.

200 Commerce Drive, Clifton Park, New York 12065-1350 • Tel: (518) 877-7444 • FAX: 518-877-5029
11611 Hart Street, North Hollywood, California 91605-5882 • Tel: (818) 982-9600 • FAX: 818-503-1102
100 Bobrick Drive, Jackson, Tennessee 38301-5635 • Tel: (731) 424-7000 • FAX: 731-424-7800

In Canada: BOBRICK WASHROOM EQUIPMENT COMPANY

45 Rolark Drive, Scarborough, Ontario M1R 3B1 • Tel: (416) 298-1611 • FAX: 416-298-6351