

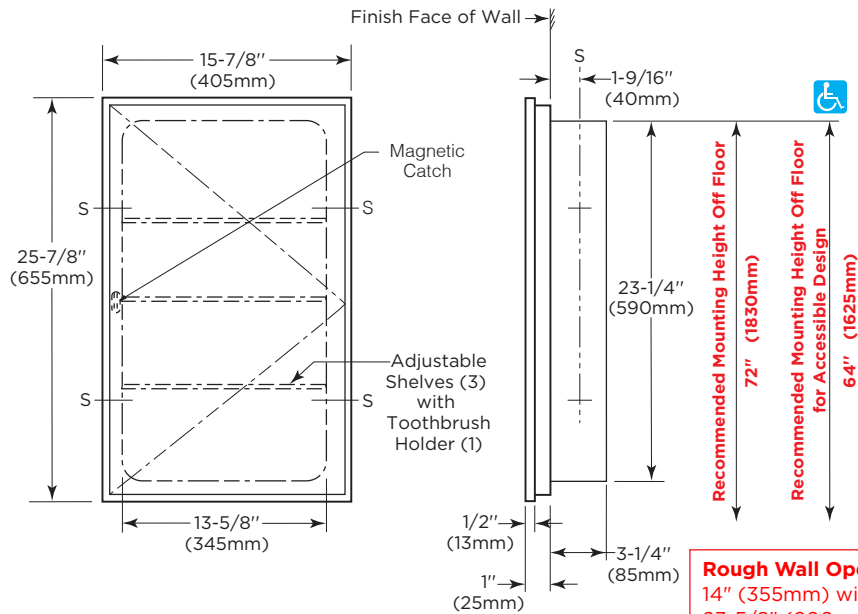

# Technical Data

# RECESSED MEDICINE CABINET

# B-397



### MATERIALS:

**Cabinet** — Heavy-gauge (24-gauge) steel with white powder-coated finish. All-welded construction.

**Door** — Heavy-gauge (22-gauge) steel with stainless steel channel frame. Secured to cabinet with an enameled steel piano-hinge and equipped with a magnetic catch.

**Mirror** — No. 1 quality, 1/4" (6mm) select float glass, electrolytically copper-plated by the galvanic process, and guaranteed for 15 years against silver spoilage. Back is protected by full-size, shock-absorbing padding.

**Adjustable Shelves (3)** — Clear plastic extrusion. Attach to cabinet by sliding into slots in sides of cabinet. One shelf is equipped with four slots to serve as toothbrush holders.

### OPERATION:

Door is retained by means of a magnetic catch. Shelves can be adjusted by locating in different slots formed on sides of cabinet. Toothbrush holder in shelf accommodates four toothbrushes.

### INSTALLATION:

Cabinet may be inverted for right- or left-hand door swing. Provide framed rough wall opening 14" wide x 23-5/8" high (355 x 600mm). Minimum recessed depth required from finish face of wall is 3-1/2" (89mm). Allow clearance for construction features that may protrude into rough wall opening from opposite wall. Coordinate with mechanical engineer to avoid pipes, vents, and conduits. If unit projects above top of wainscot, provide aluminum channel or other filler to eliminate gap between flange and finish face of wall. If units are installed back-to-back, a sound barrier is recommended between units. Mount cabinet in rough wall opening with shims between framing and cabinet at all points indicated by an S, then secure unit with sheet-metal screws furnished by manufacturer.

### SPECIFICATION:

Recessed medicine cabinet shall be heavy-gauge steel with all-welded construction. Cabinet shall have white powder-coated finish. Door shall have stainless steel channel frame, be secured to cabinet with an enameled steel piano-hinge, and equipped with a magnetic catch. Mirror shall be No. 1 quality, 1/4" (6mm) select float glass, electrolytically copper-plated. No. 1 quality, 1/4" (6mm) thick select float glass mirror shall be guaranteed against silver spoilage for 15 years and shall be mounted in door. Cabinet shall have three adjustable clear plastic shelves. One shelf shall be equipped with four slots to serve as toothbrush holders. Unit shall be invertible for right- or left-hand door swing.

**Recessed Medicine Cabinet shall be Model B-397 of Bobrick Washroom Equipment, Inc., Clifton Park, New York; Jackson, Tennessee; Los Angeles, California; Bobrick Washroom Equipment Company, Scarborough, Ontario; Bobrick Washroom Equipment Pty. Ltd., Australia; and Bobrick Washroom Equipment Limited, United Kingdom.**