

Advisory Bulletin



BUILDING VALUE SINCE 1906

TB-107 Cleaning and Maintenance For Bobrick B-824 Automatic Counter-Mounted Soap Dispensers

Quality soap dispensers require good quality soap and periodic maintenance to properly operate. For reliable long-term use, perform regular maintenance for each unit. Most soap dispenser problems are caused by soap that is too thick or corrosive, or by a lack of maintenance. If proper soap is being used, problems can still arise if dispensers have never been cleaned. Bobrick recommends a viscosity of 100 to 19,000cP. With proper maintenance and soap, Bobrick dispensers will provide long term, trouble free operation.

Deactivate the soap dispenser by placing your finger over the Fiber Optic Sensor area while you clean. The sensor is located just behind the Nozzle Tip. Once dispenser is cleaned, remove finger from the sensor area. Or unplug the Power Supply located on the bottom of the housing (LED will not light).

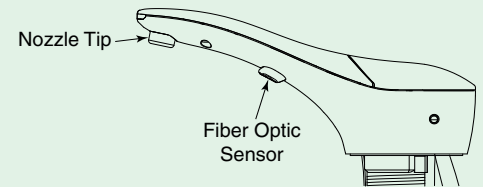

DO NOT use abrasive or chemical cleaners (including chlorine bleach) to clean Spout, as it may dull the luster and attack the chrome-plated exterior. Use ONLY mild soap and water, then wipe dry with clean cloth. While cleaning the bathroom counter top, protect the Spout from any splattering of cleaner. Acids and cleaning fluids will discolor or remove chrome plating.

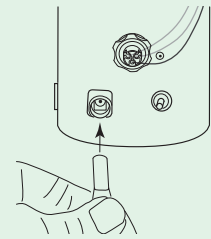

Daily cleaning:

- Using a soft, dry cloth wipe the exterior.
 - If dispenser is really dirty gently wipe the dispenser with a cloth moistened with warm water and a diluted neutral detergent. Remove the detergent with a soft damp cloth and then rub with a second soft, dry cloth.

Periodic cleaning (3 to 6 months)

- Place hand under Nozzle Tip to be sure soap is properly dispensed
- Gently wipe the dispenser with a cloth moistened with warm water and a diluted neutral detergent
- Clean area between Lid and Spout to keep Lid swing free of soap residue
- Flush the system when minimal amount of soap is left in the bottle
 - Open the top-fill door using the BobKey, rotate door clockwise
 - Fill the dispenser with warm water.
 - Press the Automatic Flush Button located on the bottom housing assembly, just above the Portion Control Knob.
 - Once unit is flushed, Press the Automatic Flush Button again to stop dispensing.
 - Fill unit with fresh soap.
- Place hand under Nozzle Tip to be sure soap is properly dispensed.

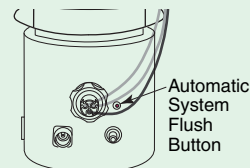
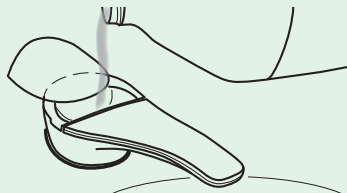



Troubleshooting Guide

for Bobrick B-824 SureFlo Automatic, Top Fill Bulk Liquid Soap Dispenser

Step 1: To determine cause: Unplug unit and reconnect unit, look for Green LED light and sound of motor. Activate soap dispenser continually five times.

Unit Not Dispensing	If motor running and LED does not light up consistently when hand is in the activation zone.			
	<i>Likely Cause</i>	<i>Action</i>	<i>Instruction</i>	<i>Replacement Part/Kit Needed</i>
	Fiber Optic Nut may be thread too tight onto connector port in the Bottom Housing.	Check Fiber Optic Nut to see if nut has been overtightened	Tighten Fiber Optic Connector Nut hand tight and then rotate nut counterclockwise by 1/4 turn (90°).	n/a
	No change.	All steps above completed.	Contact Bobrick Customer Service.	n/a
	If motor running and LED lights up when hand is in the activation zone.			
	<i>Likely Cause</i>	<i>Action</i>	<i>Instruction</i>	<i>Replacement Part/Kit Needed</i>
	Soap may be too viscous (i.e. Soap may be too thick).	Ensure that soap meets specified viscosity range. Viscosity range of 100 to 19,000cP (cP = centerpoise). Adjust portion control knob to get desired amount of soap.	Replace with soap that is within the recommended viscosity range.	n/a
	If unit requires multiple (more than 5) activations to dispense liquid. Duckbill inside Duckbill Housing missing or not installed properly.	Replace Duckbill Housing	Contact Bobrick Customer Service.	824-322
	No change.	All steps above completed.	Contact Bobrick Customer Service.	n/a
	If motor not running and LED lights up when hand is in the activation zone.			
	<i>Likely Cause</i>	<i>Action</i>	<i>Instruction</i>	<i>Replacement Part/Kit Needed</i>
	Gear jamming.	Check for dried soap. Purge system.	Open Cover, pour warm water, and then purge by pressing Automatic System Flush Button.	n/a
	Flashing red LED. Indicates sensor obstruction.	Ensure all obstructions are clear from sensor path.	Refer to mounting template 824-307 .	n/a
	No change.	All steps above completed.	Contact Bobrick Customer Service.	n/a
	If motor not running and no LED light.			
<i>Likely Cause</i>	<i>Action</i>	<i>Instruction</i>	<i>Replacement Part/Kit Needed</i>	
No power to the unit	Check A/C adapter connection.	If LED lights up then follow the steps listed under "If motor not running and LED lights up when hand is in the activation zone" .	n/a	
No change.	All steps above completed.	Contact Bobrick Customer Service.	n/a	
Unit Leaking	<i>Likely Cause</i>	<i>Action</i>	<i>Instruction</i>	<i>Replacement Part/Kit Needed</i>
	Bottle Assembly is not tight over the Stem.	Unscrew Stem Locking Nut.	While pushing upwards on the Bottle, thread the Stem Locking Nut down onto the Bottle Cap Threads. Hold the Stem and lightly rotate the Bottle back and forth to be sure there is no movement.	n/a
	Leaking from bottom of the Bottle	1. Disconnect fiber optic cables and power supply from the Bottom Housing. 2. Locate leak if from bottom of Bottom Housing.	Ensure that the bottom of the Bottle is properly tightened.	n/a
	No change.	All steps above completed.	Replace with Bottom Housing Assembly.	824-550

Unit Diagram

Item	Description
1	Top Assembly with Spout, Door and Stem
2	LED Light Pipe
3	Liquid Nozzle Tip
4	Fiber Optic Insert with Sensor Lenses
5	Rubber Counter Gasket
6	Wave Washer
7	Mounting Nut
8	Stem Mounting Nut
9	Duckbill Housing
10	Bottom Housing Assembly (includes Soap Bottle)
11	Battery Pack (requires (4) "D" cell alkaline batteries not included)
12	(3) Fiber Optic Cables for Sensor and LED Light Pipe
13	Fiber Optic Connector Tip Assembly
14	Fiber Optic Nut
15	Portion Control Knob
16	Automatic System Flush Button
17	Key Hole
18	BobKey
19	Optional: A/C Adapter Kit with U.S. Plug, Order Part No. 3974-57 (for UK, Europe and Australia, order part no. 3974-55)

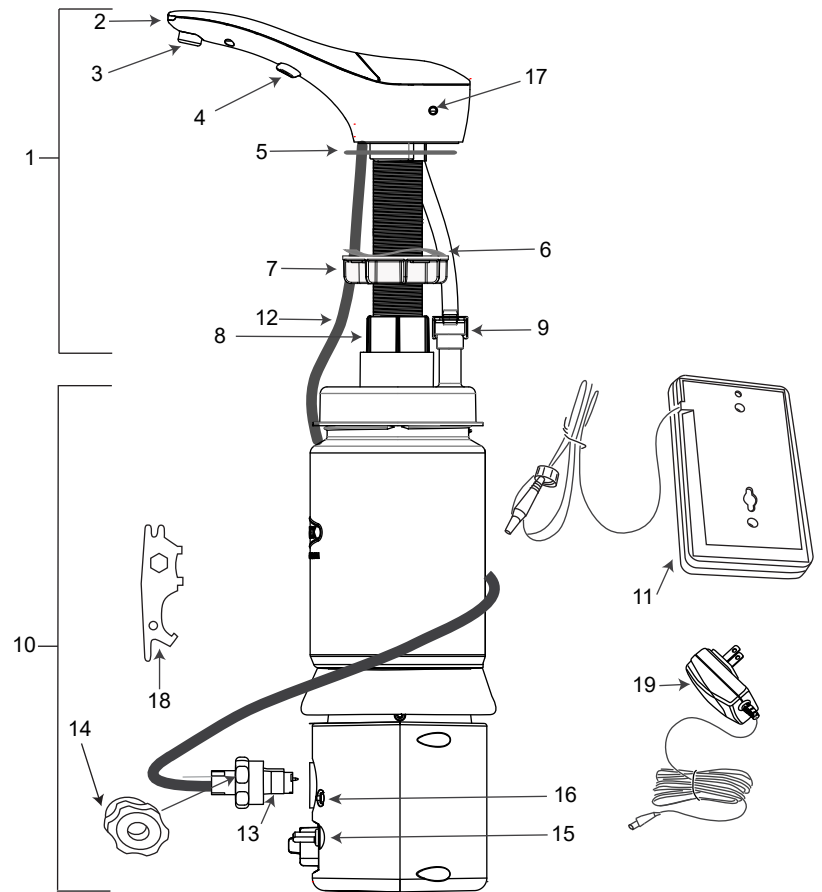

Replacement Parts List	
Description	Part #
A/C Adapter	3974-57
A/C Adapter with International Assortment Plug Kit (U. K., Europe, Australia)	3974-55
Mack Gasket Kit (To secure Top Assembly under the counter due to irregular counter surface)	824-167
External A/C Multi Adapter Kit	824-201
Nozzle Tip Replacement Kit Liquid	824-210
D Size Battery Pack (Batteries not included)	824-241
Duckbill Housing	824-322
Installation Hardware Packet (Includes Wave Washer, Counter Gasket, Mounting Nut, BobKey, Stem Mounting Nut)	824-443
Top Housing Assembly Liquid (Includes Installation Hardware Packet and Duckbill Housing)	824-525
Bottom Housing Assembly Liquid	824-550

Recommended Liquid Soaps
MAINTEX EZ Wash
Entral Pink Deluxe Soap
GOJO® Lotion Hand Cleaner
Softsoap® Moisturizing Hand Soap
Dial® Basics HypoAllergenic Liquid Hand Soap
Genlabs Strike Bac® Antibacterial Handsoap
CARROLL ULTREX Antimicrobial Luxury Hand Soap
<i>Recommended soaps are for reference only and do not constitute an endorsement of named manufacturer(s). All registrations and trademarks are the sole property of manufacturer.</i>

